

DEPARTMENT OF WATER AND SANITATION
REPUBLIC OF SOUTH AFRICA

DUE AT 11:00 ON

18 JUNE 2015

(CLOSING DATE)

BID W 1021(WTE)

THE SUPPLY AND DELIVERY OF 184 DIFFERENT FLANGES FULLY MACHINED, DRILLED
AND NORMALISED AS PER SUPPLIED DRAWINGS TO
CONSTRUCTION CENTRAL

SUBMIT BID DOCUMENTS TO:

POSTAL ADDRESS: OR
DIRECTOR-GENERAL: WATER AND SANITATION
PRIVATE BAG X313
PRETORIA, 0001

TO BE DEPOSITED IN:
THE BID BOX AT THE ENTRANCE
OF ZWAMADAKA BUILDING
173 FRANCIS BAARD STREET
PRETORIA, 0002

Compulsory Briefing Session

Date: 5 June 2015

Time: 11:00am

Venue: 173 Francis Baard Street, Emanzini Building, Room G18, Pretoria

BIDDER: (Company address and stamp)

COMPILED BY: CHIEF DIRECTORATE CONSTRUCTION MANAGEMENT

DEPARTMENT OF WATER AND SANITATION

BID W 1021(WTE)

THE SUPPLY AND DELIVERY OF 184 DIFFERENT FLANGES FULLY MACHINED, DRILLED AND NORMALISED AS
PER SUPPLIED DRAWINGS FOR CONSTRUCTION CENTRAL

CONTENTS

INVITATION TO BID (SBD 1)

SECTION 1: LEGALITIES

SECTION 2: CONDITIONS OF CONTRACT

SECTION 3: SPECIFICATIONS

SECTION 4: PRICING SCHEDULE

SECTION 5: GRADING SPECIFICATION

INVITATION TO BID

YOU ARE HEREBY INVITED TO BID FOR REQUIREMENTS OF THE DEPARTMENT OF WATER AND SANITATION

BID NUMBER: CLOSING DATE: CLOSING TIME: 11:00

The successful bidder will be required to fill in and sign a written Contract Form (SBD 7)

BID DOCUMENTS MAY BE POSTED TO: Director- General: Department of Water and Sanitation
 Private Bag X313
PRETORIA, 0001
Attention: Supply Chain Management Office
 At the entrance of ZwaMadaka Building

OR

DEPOSITED IN THE BID BOX SITUATED AT 173 FRANCIS BAARD STREET, ZWAMADAKA BUILDING, PRETORIA, 0001

Bidders should ensure that bids are delivered timeously to the correct address. If the bid is late, it will not be accepted for consideration.

The bid box is generally open 24 hours a day, 7 days a week.

ALL BIDS MUST BE SUBMITTED ON THE OFFICIAL FORMS – (NOT TO BE RE-TYPED)

THIS BID IS SUBJECT TO THE PREFERENTIAL PROCUREMENT POLICY FRAMEWORK ACT AND THE PREFERENTIAL PROCUREMENT REGULATIONS, 2011, THE GENERAL CONDITIONS OF CONTRACT (GCC) AND, IF APPLICABLE, ANY OTHER SPECIAL CONDITIONS OF CONTRACT

**THE FOLLOWING PARTICULARS MUST BE FURNISHED
 (FAILURE TO DO SO MAY RESULT IN YOUR BID BEING DISQUALIFIED)**

NAME OF BIDDER
 POSTAL ADDRESS
 STREET ADDRESS
 TELEPHONE NUMBER CODE..... NUMBER.....
 CELLPHONE NUMBER
 FACSIMILE NUMBER CODE NUMBER.....
 E-MAIL ADDRESS
 VAT REGISTRATION NUMBER

HAS AN ORIGINAL AND VALID TAX CLEARANCE CERTIFICATE BEEN SUBMITTED? (SBD 2) YES or NO

HAS A B-BBEE STATUS LEVEL VERIFICATION CERTIFICATE BEEN SUBMITTED? (SBD 6.1) YES or NO

IF YES, WHO WAS THE CERTIFICATE ISSUED BY?

- AN ACCOUNTING OFFICER AS CONTEMPLATED IN THE CLOSE CORPORATION ACT (CCA)
 - A VERIFICATION AGENCY ACCREDITED BY THE SOUTH AFRICAN ACCREDITATION SYSTEM (SANAS); OR
 - A REGISTERED AUDITOR
- [TICK APPLICABLE BOX]

(A B-BBEE STATUS LEVEL VERIFICATION CERTIFICATE MUST BE SUBMITTED IN ORDER TO QUALIFY FOR PREFERENCE POINTS FOR B-BBEE)

ARE YOU THE ACCREDITED REPRESENTATIVE IN SOUTH AFRICA FOR THE GOODS / SERVICES / WORKS OFFERED? YES or NO
[IF YES ENCLOSE PROOF]

SIGNATURE OF BIDDER

DATE.....

CAPACITY UNDER WHICH THIS BID IS SIGNED.....

TOTAL BID PRICE..... TOTAL NUMBER OF ITEMS OFFERED

ANY ENQUIRIES REGARDING THE BIDDING PROCEDURE MAY BE DIRECTED TO:

Department: Water and Sanitation

Contact Person: Miss Julia Dirane

Tel: (012) 366 7780

Fax: (012) 325 6111

E-mail address: DiraneJ@dwa.gov.za

ANY ENQUIRIES REGARDING TECHNICAL INFORMATION MAY BE DIRECTED TO:

Contact Person: Mr Johan Oosthuizen

Tel: 053 456 0508

E-mail address: doep@dwa.gov.za

Contact Person: Mr B.A. Marais

Tel: 053 456 0508

E-mail address: groenewaldj2@dwa.gov.za

DEPARTMENT OF WATER AND SANITATION

BID W 1021(WTE)

THE SUPPLY AND DELIVERY OF 184 DIFFERENT FLANGES FULLY MACHINED, DRILLED AND NORMALISED AS
PER SUPPLIED DRAWINGS FOR CONSTRUCTION CENTRAL

SECTION 1: LEGALITIES

CONTENTS

1. Instructions to Bidders
2. Tax Clearance Requirements (SBD 2)
3. Declaration of Interest (SBD 4)
4. Declaration of Bidders Past Supply Chain Management Practices (SBD 8)
5. Preference Points Claim in terms of the Preferential Procurement Regulation, 2011 (SBD 6.1)
6. Instructions to Bidders: Purchases (ANNEXURE 7)
7. Certificate of Independent bid Determination (SBD 9)
8. Vendor Master Form (SAP)

DEPARTMENT OF WATER AND SANITATION

BID W 1021(WTE)

THE SUPPLY AND DELIVERY OF 184 DIFFERENT FLANGES FULLY MACHINED, DRILLED AND NORMALISED AS PER SUPPLIED DRAWINGS FOR CONSTRUCTION CENTRAL

1. INSTRUCTIONS TO BIDDERS

CONTENTS

1. Issuing of documents
2. Queries with respect to this bid
3. Completion of Bids
4. Submission of Bids
5. Signature on Bids
6. General Conditions of Contract
7. Form SBD 1
8. Preference Points
9. Bids to comply with documents
10. Telegraphic bids
11. The Department's right to decline any bid
12. Department is not liable for Bidder's expenses
13. Payments made under this contract
14. Evaluation Criteria
15. Rejection of bids
16. Results of bids

INSTRUCTIONS TO BIDDERS

1. ISSUING OF DOCUMENTS

- (a) A document is issued to a prospective Bidder. These documents are obtainable from:

Supply Chain Office
Entrance Emanzini Building (G17)
173 Francis Baard Street
PRETORIA
0002

Tel.: 012-336-7418 or 336 6979

- (b) Bidders must satisfy themselves that the document is complete and conform to the index of this document. Should any figures or writing be indistinct or should any pages be missing from this document or should this document or the drawing(s) contain any obvious errors, the Bidders must immediately notify the Department in order to have any discrepancy rectified or clarified before submitting his bid. Such clarification will be valid only if made by the Department by means of formal amendment as described hereunder prior to the date of submission of bids. The Department may issue amendments to clarify or modify the Bid Documents. A copy of each amendment will be issued to each bidder and shall be acknowledged on the form issued with the amendments. No claim whatsoever will be entertained for faults in the bid price resulting from the above-mentioned discrepancies.
- (c) No alterations, omissions or additions shall be made to this document, but should it be deemed necessary to do so, the Bidder is at liberty to qualify his bid.
- (d) All Bidders shall be deemed to have waived, renounced and abandoned any conditions printed or written upon any stationery used by them for the purpose of or in connection with the submission of bids which are in conflict with the conditions laid down in this document.

2. QUERIES WITH RESPECT TO THIS BID

Queries of a specific technical nature may be discussed personally or telephonically with Mr. Johan Oosthuisen, telephone 053 4560508 or may be directed in writing to: Workshop Manager : Construction Central , Department of Water and Sanitation , Private Bag X 6 , Jan Kempdorp , 8550.

3. COMPLETION OF BIDS

- (a) The bid must be signed on the Invitation to Bid form (SBD 1) annexed hereto with all blanks in the bid and the appendix filled in.
- (b) All spaces in the bid forms and other annexure shall be completed in full.
- (c) Section 3 in the bid document and the Pricing Schedule must be fully completed and priced out by the bidder. Failure to do so will deem your bid invalid.
- (d) The bid documents shall not be separated in any way nor must any pages be detached from the original documents.

4. SUBMISSION OF BIDS

Two copies of the Bid Documents shall be duly completed, signed and submitted as follows:

- (a) The original Bid, together with a covering letter and supporting documents, shall be sealed in an envelope endorsed:

"ORIGINAL BID FOR BID W 1021(WTE): FOR THE SUPPLY AND DELIVERY OF 184 DIFFERENT FLANGES FULLY MACHINED; DRILLED AND NORMALISED AS PER SUPPLIED DRAWINGS TO CONSTRUCTION CENTRAL " and the name of the Bidder shall be clearly shown.

- (b) The duplicate copy of the Bid, together with duplicate copies of the covering letter and supporting documents, shall be sealed in a separate envelope endorsed:

"DUPLICATE OF ORIGINAL BID FOR BID W 1021(WTE): THE SUPPLY AND DELIVERY OF 184 DIFFERENT FLANGES FULLY MACHINED , DRILLED AND NORMALISED AS PER SUPPLIED DRAWINGS FOR CONSTRUCTION CENTRAL name of the Bidder shall be clearly shown.

- (c) Both the "Original" and "Duplicate" copies of the Bid, each in their separate sealed envelopes, shall be placed in a single sealed envelope endorsed:

"ORIGINAL BID FOR BID W 1021(WTE): THE SUPPLY AND DELIVERY OF 184 DIFFERENT FLANGES FULLY MACHINED , DRILLED AND NORMALISED AS PER SUPPLIED DRAWINGS FOR CONSTRUCTION and the name of the Bidder shall be clearly shown.

- (d) Bids in duplicate, sealed and endorsed as above, will be received by: The Supply Chain Management Office Entrance Emanzini Building (G17) 173 Francis Baard Street PRETORIA 0002 at 11:00 on the date stipulated on the front cover of this document.

5. SIGNATURE ON BIDS

The Bid, if by an individual, must be signed by that individual or by someone on his behalf duly authorised thereto and proof of such authority must be produced. If the bid is by a Company it must be signed by a person duly authorised thereto by a Resolution of a Board of Directors a copy of which Resolution, duly certified by the Chairman of the Company is to be submitted with the bid.

The successful bidder will be required to submit a "Letter from the manufacturer" confirming the supply arrangement within 14 days after the approval of the bid.

If the bid is submitted by joint venture of more than one person and/or Companies and/or firms it shall be accompanied by the following:

- (a) The original or a naturally certified copy of the original document under which such joint venture was constituted which must define precisely inter alia the conditions under which the joint venture will function, its period of duration and the participation of the several constituent persons and/or companies and/or firms.
- (b) A certificate signed by or on behalf of each participating person and/or company and/or firm authorising the person who signed the bid to do so.

6. GENERAL CONDITIONS OF CONTRACT

The General Conditions of Contract shall be regarded as an integral part of the contract documents.

7. FORM SBD 1

The copy of Form SBD 1 (Invitation to Bid), annexed to these documents, must be completed and signed by the Bidder. Failure to do so will deem your bid invalid.

8. PREFERENCE FOR EQUITY OWNERSHIP

Bidder desirous of claiming preference for equity ownership by previously disadvantaged individuals/women must fully complete and sign Form SBD 6.1 or no preference will be allowed. A copy of your company registration forms and a valid accredited B-BBEE Status Level Verification Certificate **must** be submitted with the bid document.

NOTICE TO ALL POTENTIAL BIDDERS

PLEASE NOTE THAT PREFERENCE POINTS CLAIMED IN THE STANDARD BIDDING DOCUMENT PROVIDED WILL BE AUDITED BY AN INDEPENDENT PROFESSIONAL SERVICE PROVIDER. SUPPLIERS THAT PROVIDE INCORRECT OR FALSE INFORMATION REGARDING THE OWNERSHIP OF THEIR COMPANY, RUNS THE RISK OF BEING PROSECUTED WITH THE POSSIBLE RESTRICTION FROM PARTICIPATING IN CONTRACT WITH ANY DEPARTMENT IN THE SPHERE OF GOVERNMENT. PARTICULAR ATTENTION SHOULD BE GIVEN TO THE CONTENT OF SBD 6.1, PARAGRAPH 9.8.

9. BIDDERS TO COMPLY WITH DOCUMENTS

Where applicable, Bidders must allow in their Bids for all labour, material, machinery and everything necessary for the execution and completion of the Contract in accordance with the bid documents. No alterations may be made in the Invitation to Bid, Schedule of Quantities or other documents and the bid will be deemed to comply entirely with the terms of the documents.

10. TELEGRAPHIC BIDS

No bid forwarded by telegram, telex, facsimile, e-mail or similar apparatus will be considered.

11. THE DEPARTMENT'S RIGHT TO DECLINE ANY BID

The Department does not bind itself to accept the lowest or any bid.

12. DEPARTMENT NOT LIABLE FOR BIDDER'S EXPENSES

The Department will not be held liable for any expenses incurred in preparing and submitting bids.

13. PAYMENTS UNDER THE CONTRACT

All payments due to the Contractor in terms of the contract will be done by means of Electronic Fund Transfer.

Contractors must provide the necessary details of their bank account in a standardised form supplied by the department (SAP Vendor Master Form).

14. EVALUATION CRITERIA

The evaluation Committee will be following a phased approach during the evaluation.

Phase 1

Administrative Compliance:

Bidders are required to submit and or complete the following documents which should form part of the bid submitted by closing date. Omission to complete and/or submit the listed documents will render your bid non responsive and the bid will not be considered for the phase 2 evaluation.

- (a) An original and valid tax clearance certificate
- (b) The pricing schedule (SBD3.2)
- (c) Completion and inclusion of standard bidding documents.
(SBD1, SBD4, SBD6.1, SBD8, SBD9)
- (d) Proof of compliance certificate of SANS 1123 mild steel grade 350WA or equivalent or issued by other countries.
- (e) Compulsory briefing session should be attended (Signing of attendance register).

Phase 2

Technical Compliance:

The bid will be evaluated using the below criteria and failure to comply with **all** the specifications as listed will render your bid as not to specification and non responsive and the bid will not be considered for the phase 3 evaluation.

- (a) Standard Specifications as set out under Section 3: Specifications and the compliance thereof
- (b) The bid will be rendered non responsive if the bidder fails to complete the "Comply / Not Comply" in the Specification under Section 3: Specifications

Phase 3

Evaluation of price and preference points claimed:

B-BBEE Points

During this phase, bid proposals that passed the phase two will be further evaluated based on the 90/10 preference points system in accordance with the PPPFA Act, where 90 points will be attained in respect of price and 10 points will be awarded to a bidder for attaining the B-BBEE Status Level of Contribution in accordance with the table below:

B-BBEE Status Level of Contributor	Number of points (90/10 system)
1	10
2	9
3	8
4	5
5	4
6	3
7	2
8	1
Non-compliant contributor	0

In order to claim the B-BBEE Status Level of Contributor points, bidders must submit original and valid B-BBEE Status Level Verification Certificates or certified copies thereof, issued by accredited Verification Agency/s by SANAS or 11.2.3.2 Registered Auditor approved by Independent Regulatory Board of Auditor (IRBA), together with their bids to substantiate their B-BBEE rating claims. The Exempted Micro Enterprise must submit a letter from the Accounting Officer who is appointed in terms of Close Corporation Act.

Bidders who do not submit B-BBEE Status Level Verification Certificates or are non-compliant contributors to B-BBEE do not qualify for preference points for B-BBEE but will not be disqualified from the bidding process. They will score points out of 90 for price only and zero (0) points out of 10 for B-BBEE.

Bidders are requested to complete the preference claim form in order to claim preference points. The points scored by a bidder in respect of points indicated above will be added to the points scored for price.

The highest ranked bidder will be awarded the bid. It should be noted also that the Department reserve the right not to appoint any service provider.

A person will not be awarded points for B-BBEE status level if it is indicated in the bid documents that such bidder intends sub-contracting more than 25% of the value of the contract to any other enterprise that does not qualify for, unless the intended sub-contractor is an EME that has the capability and ability to execute the sub-contract.

A person awarded a contract may not sub-contract more than 25% of the value of the contract to any other enterprise that does not have an equal or higher B-BBEE status level than the person concerned, unless the contract is sub-contracted to an EME that has the capability to execute the sub-contract.

15. REJECTION OF BID

Bids not complying with the above-mentioned requirements and specifications may be regarded as incomplete and may not be considered.

16. RESULTS OF BIDS

Results of non-acceptance of bids will be sent to individual unsuccessful bidders.

TAX CLEARANCE CERTIFICATE REQUIREMENTS

It is a condition of bid that the taxes of the successful bidder must be in order, or that satisfactory arrangements have been made with South African Revenue Service (SARS) to meet the bidder's tax obligations.

- 1 In order to meet this requirement bidders are required to complete in full the attached form TCC 001 "Application for a Tax Clearance Certificate" and submit it to any SARS branch office nationally. The Tax Clearance Certificate Requirements are also applicable to foreign bidders / individuals who wish to submit bids.
- 2 SARS will then furnish the bidder with a Tax Clearance Certificate that will be valid for a period of 1 (one) year from the date of approval.
- 3 The original Tax Clearance Certificate must be submitted together with the bid. Failure to submit the original and valid Tax Clearance Certificate will result in the invalidation of the bid. Certified copies of the Tax Clearance Certificate will not be acceptable.
- 4 In bids where Consortia / Joint Ventures / Sub-contractors are involved, each party must submit a separate Tax Clearance Certificate.
- 5 Copies of the TCC 001 "Application for a Tax Clearance Certificate" form are available from any SARS branch office nationally or on the website www.sars.gov.za.
- 6 Applications for the Tax Clearance Certificates may also be made via eFiling. In order to use this provision, taxpayers will need to register with SARS as eFilers through the website www.sars.gov.za.



TAX CLEARANCE



Application for a Tax Clearance Certificate

Purpose

Select the applicable option Tenders Good standing
If "Good standing", please state the purpose of this application

Particulars of applicant

Name/Legal name
(Initials & Surname
or registered name)

Trading name
(if applicable)

ID/Passport no

Income Tax ref no

VAT registration no 4

Customs code

Telephone no

E-mail address

Physical address

Company/Close Corp.
registered no

PAYE ref no 7

SDL ref no L

UIF ref no U

Fax
no

Postal address

Particulars of representative (Public Officer/Trustee/Partner)

Surname

First names

ID/Passport no

Telephone no

E-mail address

Physical address

Income Tax ref no

Fax
no

Particulars of tender (if applicable)

Tender number

Estimated Tender amount R

Expected duration of the tender year(s)

Particulars of the 3 largest contracts previously awarded

Date started	Date finalised	Principal	Contact person	Telephone number	Amount
--------------	----------------	-----------	----------------	------------------	--------

Audit

Are you currently aware of any Audit investigation against you/the company? If "YES" provide details YES NO

Appointment of representative/agent (Power of Attorney)

I the undersigned confirm that I require a Tax Clearance Certificate in respect of Tenders or Goodstanding.

I hereby authorise and instruct SARS the applicable Tax Clearance Certificate on my/our behalf. to apply to and receive from

Name of representative/agent

Signature of representative/agent

Date

Declaration

I declare that the information furnished in this application as well as any supporting documents is true and correct in every respect.

Name of applicant/Public Officer

Signature of applicant/Public Officer

Date

Notes:

- It is a serious offence to make a false declaration.
- Section 75 of the Income Tax Act, 1962, states: Any person who
 - fails or neglects to furnish, file or submit any return or document as and when required by or under this Act; or
 - without just cause shown by him, refuses or neglects to-
 - furnish, produce or make available any information, documents or things;
 - reply to or answer truly and fully, any questions put to him ...

As and when required in terms of this Act ... shall be guilty of an offence ...
- SARS will, under no circumstances, issue a Tax Clearance Certificate unless this form is completed in full.
- Your Tax Clearance Certificate will only be issued on presentation of your South African Identity Document or Passport (Foreigners only) as applicable.

DECLARATION OF INTEREST

1. Any legal person, including persons employed by the state¹, or persons having a kinship with persons employed by the state, including a blood relationship, may make an offer or offers in terms of this invitation to bid (includes an advertised competitive bid, a limited bid, a proposal or written price quotation). In view of possible allegations of favouritism, should the resulting bid, or part thereof, be awarded to persons employed by the state, or to persons connected with or related to them, it is required that the bidder or his/her authorised representative declare his/her position in relation to the evaluating/adjudicating authority where-

- the bidder is employed by the state; and/or
- the legal person on whose behalf the bidding document is signed, has a relationship with persons/a person who are/is involved in the evaluation and or adjudication of the bid(s), or where it is known that such a relationship exists between the person or persons for or on whose behalf the declarant acts and persons who are involved with the evaluation and or adjudication of the bid.

2. In order to give effect to the above, the following questionnaire must be completed and submitted with the bid.

2.1 Full Name of bidder or his or her representative:

2.2 Identity Number:

2.3 Position occupied in the Company (director, trustee, shareholder², member):
.....

2.4 Registration number of company, enterprise, close corporation, partnership agreement or trust:
.....

2.5 Tax Reference Number:

2.6 VAT Registration Number:

2.6.1 The names of all directors / trustees / shareholders / members, their individual identity numbers, tax reference numbers and, if applicable, employee / PERSAL numbers must be indicated in paragraph 3 below.

¹"State" means -

- (a) any national or provincial department, national or provincial public entity or constitutional institution within the meaning of the Public Finance Management Act, 1999 (Act No. 1 of 1999);
- (b) any municipality or municipal entity;
- (c) provincial legislature;
- (d) national Assembly or the national Council of provinces; or
- (e) Parliament.

²"Shareholder" means a person who owns shares in the company and is actively involved in the management of the enterprise or business and exercises control over the enterprise.

2.7 Are you or any person connected with the bidder presently employed by the state? YES / NO

2.7.1 If so, furnish the following particulars:

Name of person / director / trustee / shareholder/ member:
Name of state institution at which you or the person connected to the bidder is employed :
Position occupied in the state institution:

Any other particulars:
.....
.....
.....

2.7.2 If you are presently employed by the state, did you obtain the appropriate authority to undertake remunerative work outside employment in the public sector? YES / NO

2.7.2.1 If yes, did you attach proof of such authority to the bid document? YES / NO

(Note: Failure to submit proof of such authority, where applicable, may result in the disqualification of the bid.

2.7.2.2.1 If no, furnish reasons for non-submission of such proof:

.....
.....
.....

2.8 Did you or your spouse, or any of the company's directors / trustees / shareholders / members or their spouses conduct business with the state in the previous twelve months? YES / NO

2.8.1 If so, furnish particulars:

.....
.....
.....

2.9 Do you, or any person connected with the bidder, have any relationship (family, friend, other) with a person employed by the state and who may be involved with the evaluation and or adjudication of this bid? YES / NO

2.9.1 If so, furnish particulars.

.....
.....
.....

DECLARATION OF BIDDER'S PAST SUPPLY CHAIN MANAGEMENT PRACTICES

- 1 This Standard Bidding Document must form part of all bids invited.
- 2 It serves as a declaration to be used by institutions in ensuring that when goods and services are being procured, all reasonable steps are taken to combat the abuse of the supply chain management system.
- 3 The bid of any bidder may be disregarded if that bidder, or any of its directors have-
 - a. abused the institution's supply chain management system;
 - b. committed fraud or any other improper conduct in relation to such system; or
 - c. failed to perform on any previous contract.
- 4 In order to give effect to the above, the following questionnaire must be completed and submitted with the bid.

Item	Question	Yes	No
4.1	Is the bidder or any of its directors listed on the National Treasury's Database of Restricted Suppliers as companies or persons prohibited from doing business with the public sector? (Companies or persons who are listed on this Database were informed in writing of this restriction by the Accounting Officer/Authority of the institution that imposed the restriction after the <i>audi alteram partem</i> rule was applied). The Database of Restricted Suppliers now resides on the National Treasury's website (www.treasury.gov.za) and can be accessed by clicking on its link at the bottom of the home page.	Yes <input type="checkbox"/>	No <input type="checkbox"/>
4.1.1	If so, furnish particulars:		
4.2	Is the bidder or any of its directors listed on the Register for Tender Defaulters in terms of section 29 of the Prevention and Combating of Corrupt Activities Act (No 12 of 2004)? The Register for Tender Defaulters can be accessed on the National Treasury's website (www.treasury.gov.za) by clicking on its link at the bottom of the home page.	Yes <input type="checkbox"/>	No <input type="checkbox"/>
4.2.1	If so, furnish particulars:		
4.3	Was the bidder or any of its directors convicted by a court of law (including a court outside of the Republic of South Africa) for fraud or corruption during the past five years?	Yes <input type="checkbox"/>	No <input type="checkbox"/>
4.3.1	If so, furnish particulars:		
4.4	Was any contract between the bidder and any organ of state terminated during the past five years on account of failure to perform on or comply with the contract?	Yes <input type="checkbox"/>	No <input type="checkbox"/>
4.4.1	If so, furnish particulars:		

CERTIFICATION

I, THE UNDERSIGNED (FULL NAME).....
CERTIFY THAT THE INFORMATION FURNISHED ON THIS DECLARATION FORM IS TRUE AND
CORRECT.

I ACCEPT THAT, IN ADDITION TO CANCELLATION OF A CONTRACT, ACTION MAY BE TAKEN
AGAINST ME SHOULD THIS DECLARATION PROVE TO BE FALSE.*

.....
Signature

.....
Date

.....
Position

.....
Name of Bidder

November 2011

PREFERENCE POINTS CLAIM FORM IN TERMS OF THE PREFERENTIAL PROCUREMENT REGULATIONS 2011

This preference form must form part of all bids invited. It contains general information and serves as a claim form for preference points for Broad-Based Black Economic Empowerment (B-BBEE) Status Level of Contribution

NB: BEFORE COMPLETING THIS FORM, BIDDERS MUST STUDY THE GENERAL CONDITIONS, DEFINITIONS AND DIRECTIVES APPLICABLE IN RESPECT OF B-BBEE, AS PRESCRIBED IN THE PREFERENTIAL PROCUREMENT REGULATIONS, 2011.

1. GENERAL CONDITIONS

1.1 The following preference point systems are applicable to all bids:

- the 80/20 system for requirements with a Rand value of up to R1 000 000 (all applicable taxes included); and
- the 90/10 system for requirements with a Rand value above R1 000 000 (all applicable taxes included).

1.2 The value of this bid is estimated to exceed/not exceed R1 000 000 (all applicable taxes included) and therefore the **90/10** system shall be applicable.

1.3 Preference points for this bid shall be awarded for:

- (a) Price; and
- (b) B-BBEE Status Level of Contribution.

1.3.1 The maximum points for this bid are allocated as follows:

	POINTS
1.3.1.1 PRICE	90
1.3.1.2 B-BBEE STATUS LEVEL OF CONTRIBUTION	10
Total points for Price and B-BBEE must not exceed	100

1.4 Failure on the part of a bidder to fill in and/or to sign this form and submit a B-BBEE Verification Certificate from a Verification Agency accredited by the South African Accreditation System (SANAS) or a Registered Auditor approved by the Independent Regulatory Board of Auditors (IRBA) or an Accounting Officer as contemplated in the Close Corporation Act (CCA) together with the bid, will be interpreted to mean that preference points for B-BBEE status level of contribution are not claimed.

1.5 The purchaser reserves the right to require of a bidder, either before a bid is adjudicated or at any time subsequently, to substantiate any claim in regard to preferences, in any manner required by the purchaser.

2. DEFINITIONS

2.1 "all applicable taxes" includes value-added tax, pay as you earn, income tax, unemployment insurance fund contributions and skills development levies;

2.2 "B-BBEE" means broad-based black economic empowerment as defined in section 1 of the Broad-Based Black Economic Empowerment Act;

- 2.3 **"B-BBEE status level of contributor"** means the B-BBEE status received by a measured entity based on its overall performance using the relevant scorecard contained in the Codes of Good Practice on Black Economic Empowerment, issued in terms of section 9(1) of the Broad-Based Black Economic Empowerment Act;
- 2.4 **"bid"** means a written offer in a prescribed or stipulated form in response to an invitation by an organ of state for the provision of services, works or goods, through price quotations, advertised competitive bidding processes or proposals;
- 2.5 **"Broad-Based Black Economic Empowerment Act"** means the Broad-Based Black Economic Empowerment Act, 2003 (Act No. 53 of 2003);
- 2.6 **"comparative price"** means the price after the factors of a non-firm price and all unconditional discounts that can be utilized have been taken into consideration;
- 2.7 **"consortium or joint venture"** means an association of persons for the purpose of combining their expertise, property, capital, efforts, skill and knowledge in an activity for the execution of a contract;
- 2.8 **"contract"** means the agreement that results from the acceptance of a bid by an organ of state;
- 2.9 **"EME"** means any enterprise with an annual total revenue of R5 million or less .
- 2.10 **"Firm price"** means the price that is only subject to adjustments in accordance with the actual increase or decrease resulting from the change, imposition, or abolition of customs or excise duty and any other duty, levy, or tax, which, in terms of the law or regulation, is binding on the contractor and demonstrably has an influence on the price of any supplies, or the rendering costs of any service, for the execution of the contract;
- 2.11 **"functionality"** means the measurement according to predetermined norms, as set out in the bid documents, of a service or commodity that is designed to be practical and useful, working or operating, taking into account, among other factors, the quality, reliability, viability and durability of a service and the technical capacity and ability of a bidder;
- 2.12 **"non-firm prices"** means all prices other than "firm" prices;
- 2.13 **"person"** includes a juristic person;
- 2.14 **"rand value"** means the total estimated value of a contract in South African currency, calculated at the time of bid invitations, and includes all applicable taxes and excise duties;
- 2.15 **"sub-contract"** means the primary contractor's assigning, leasing, making out work to, or employing, another person to support such primary contractor in the execution of part of a project in terms of the contract;
- 2.16 **"total revenue"** bears the same meaning assigned to this expression in the Codes of Good Practice on Black Economic Empowerment, issued in terms of section 9(1) of the Broad-Based Black Economic Empowerment Act and promulgated in the *Government Gazette* on 9 February 2007;
- 2.17 **"trust"** means the arrangement through which the property of one person is made over or bequeathed to a trustee to administer such property for the benefit of another person; and
- 2.18 **"trustee"** means any person, including the founder of a trust, to whom property is bequeathed in order for such property to be administered for the benefit of another person.
- 3. ADJUDICATION USING A POINT SYSTEM**
- 3.1 The bidder obtaining the highest number of total points will be awarded the contract.
- 3.2 Preference points shall be calculated after prices have been brought to a comparative basis taking into account all factors of non-firm prices and all unconditional discounts;.

- 3.3 Points scored must be rounded off to the nearest 2 decimal places.
- 3.4 In the event that two or more bids have scored equal total points, the successful bid must be the one scoring the highest number of preference points for B-BBEE.
- 3.5 However, when functionality is part of the evaluation process and two or more bids have scored equal points including equal preference points for B-BBEE, the successful bid must be the one scoring the highest score for functionality.
- 3.6 Should two or more bids be equal in all respects, the award shall be decided by the drawing of lots.

4. POINTS AWARDED FOR PRICE

4.1 THE 80/20 OR 90/10 PREFERENCE POINT SYSTEMS

A maximum of 80 or 90 points is allocated for price on the following basis:

$$P_s = 80 \left(1 - \frac{P_t - P_{\min}}{P_{\min}} \right) \quad \text{or} \quad P_s = 90 \left(1 - \frac{P_t - P_{\min}}{P_{\min}} \right)$$

Where

- P_s = Points scored for comparative price of bid under consideration
- P_t = Comparative price of bid under consideration
- P_{\min} = Comparative price of lowest acceptable bid

5. POINTS AWARDED FOR B-BBEE STATUS LEVEL OF CONTRIBUTION

- 5.1 In terms of Regulation 5 (2) and 6 (2) of the Preferential Procurement Regulations, preference points must be awarded to a bidder for attaining the B-BBEE status level of contribution in accordance with the table below:

B-BBEE Status Level of Contributor	Number of points (90/10 system)	Number of points (80/20 system)
1	10	20
2	9	18
3	8	16
4	5	12
5	4	8
6	3	6
7	2	4
8	1	2

Non-compliant contributor	0	0
---------------------------	---	---

- 5.2 Bidders who qualify as EMEs in terms of the B-BBEE Act must submit a certificate issued by an Accounting Officer as contemplated in the CCA or a Verification Agency accredited by SANAS or a Registered Auditor. Registered auditors do not need to meet the prerequisite for IRBA's approval for the purpose of conducting verification and issuing EMEs with B-BBEE Status Level Certificates.
- 5.3 Bidders other than EMEs must submit their original and valid B-BBEE status level verification certificate or a certified copy thereof, substantiating their B-BBEE rating issued by a Registered Auditor approved by IRBA or a Verification Agency accredited by SANAS.
- 5.4 A trust, consortium or joint venture, will qualify for points for their B-BBEE status level as a legal entity, provided that the entity submits their B-BBEE status level certificate.
- 5.5 A trust, consortium or joint venture will qualify for points for their B-BBEE status level as an unincorporated entity, provided that the entity submits their consolidated B-BBEE scorecard as if they were a group structure and that such a consolidated B-BBEE scorecard is prepared for every separate bid.
- 5.6 Tertiary institutions and public entities will be required to submit their B-BBEE status level certificates in terms of the specialized scorecard contained in the B-BBEE Codes of Good Practice.
- 5.7 A person will not be awarded points for B-BBEE status level if it is indicated in the bid documents that such a bidder intends sub-contracting more than 25% of the value of the contract to any other enterprise that does not qualify for at least the points that such a bidder qualifies for, unless the intended sub-contractor is an EME that has the capability and ability to execute the sub-contract.
- 5.8 A person awarded a contract may not sub-contract more than 25% of the value of the contract to any other enterprise that does not have an equal or higher B-BBEE status level than the person concerned, unless the contract is sub-contracted to an EME that has the capability and ability to execute the sub-contract.

6. BID DECLARATION

- 6.1 Bidders who claim points in respect of B-BBEE Status Level of Contribution must complete the following:

7. B-BBEE STATUS LEVEL OF CONTRIBUTION CLAIMED IN TERMS OF PARAGRAPHS 1.3.1.2 AND 5.1

- 7.1 B-BBEE Status Level of Contribution: =(maximum of 10 or 20 points)

(Points claimed in respect of paragraph 7.1 must be in accordance with the table reflected in paragraph 5.1 and must be substantiated by means of a B-BBEE certificate issued by a Verification Agency accredited by SANAS or a Registered Auditor approved by IRBA or an Accounting Officer as contemplated in the CCA).

8. SUB-CONTRACTING

- 8.1 Will any portion of the contract be sub-contracted? YES / NO (delete which is not applicable)

8.1.1 If yes, indicate:

- (i) what percentage of the contract will be subcontracted? %
- (ii) the name of the sub-contractor?
- (iii) the B-BBEE status level of the sub-contractor?
- (iv) whether the sub-contractor is an EME? YES / NO (delete which is not applicable)

9. DECLARATION WITH REGARD TO COMPANY/FIRM

9.1 Name of company/firm

9.2 VAT registration number

9.3 Company registration number

9.4 TYPE OF COMPANY/ FIRM

- Partnership/Joint Venture / Consortium
 - One person business/sole propriety
 - Close corporation
 - Company
 - (Pty) Limited
- [TICK APPLICABLE BOX]

9.5 DESCRIBE PRINCIPAL BUSINESS ACTIVITIES

.....
.....
.....

9.6 COMPANY CLASSIFICATION

- Manufacturer
 - Supplier
 - Professional service provider
 - Other service providers, e.g. transporter, etc.
- [TICK APPLICABLE BOX]

9.7 Total number of years the company/firm has been in business?

9.8 I/we, the undersigned, who is / are duly authorised to do so on behalf of the company/firm, certify that the points claimed, based on the B-BBE status level of contribution indicated in paragraph 7 of the foregoing certificate, qualifies the company/ firm for the preference(s) shown and I / we acknowledge that:

- (i) The information furnished is true and correct;
- (ii) The preference points claimed are in accordance with the General Conditions as indicated in paragraph 1 of this form.
- (iii) In the event of a contract being awarded as a result of points claimed as shown in paragraph 7, the contractor may be required to furnish documentary proof to the satisfaction of the purchaser that the claims are correct;
- (iv) If the B-BBEE status level of contribution has been claimed or obtained on a fraudulent basis or any of the conditions of contract have not been fulfilled, the purchaser may, in addition to any other remedy it may have –

- (a) disqualify the person from the bidding process;
- (b) recover costs, losses or damages it has incurred or suffered as a result of that person's conduct;
- (c) cancel the contract and claim any damages which it has suffered as a result of having to make less favourable arrangements due to such cancellation;
- (d) restrict the bidder or contractor, its shareholders and directors, or only the shareholders and directors who acted on a fraudulent basis, from obtaining business from any organ of state for a period not exceeding 10 years, after the audi alteram partem (hear the other side) rule has been applied; and
- (e) forward the matter for criminal prosecution

WITNESSES:

1.

.....
SIGNATURE(S) OF BIDDER(S)

2.

DATE:.....

ADDRESS:.....

.....

.....

DEPARTMENT OF WATER AND SANITATION

INSTRUCTIONS TO BIDDERS: PURCHASES

1. The standard bidding forms should not be retyped or redrafted but photocopies may be prepared and used. Additional offers may be made of any item but only on a photocopy of the page in question or on other forms obtainable from the Head of Procurement: Department of Water and Sanitation, Private Bag X313, Pretoria, 0001, Attention: Supply Chain Management Office. Additional offers made in any other manner may be disregarded.
2. Should standard bid forms not be filled in by means of mechanical devices, for example typewriters, ink, preferably black, must be used to fill in bids.
3. Bidders shall check the numbers of the pages and satisfy themselves that none are missing or duplicated. No liability shall be accepted in regard to claims arising from the fact that pages are missing or duplicated.
4. Where items are specified in detail, the specifications form an integral part of the bid document and bidders shall indicate in the space provided whether the items offered are to specification or not.
5. In respect of the paragraphs where the items offered are strictly to specification, bidders shall insert the words "as specified".
6. In cases where the items are not to specification, the deviations from the specifications shall be indicated.
7. The bid prices shall be given in the units shown.
8. With the exception of basic prices, where required, all prices shall be quoted in South African currency.
9. Delivery basis:
 - (a) Supplies which are held in stock or are in transit or on order from South African manufacturers at the date of bid, shall be offered on a basis of delivery into consignee's store or on his site within the free delivery area of the bidder's centre, or carriage paid consignee's station if the goods are required elsewhere.
 - (b) Notwithstanding the provisions of paragraph 9(a), bid prices for supplies in respect of which installation/erection/assembly is a requirement, shall include ALL costs on a basis of delivered on site as specified.
10. Unless specifically provided for in the bid document, no bids transmitted by telegram, telex, facsimile, e-mail or similar apparatus shall be considered.

ANNEXURE 7

11. Bids received after the closing date and time are late and will as a rule not be accepted for consideration.
12. Bids will be opened in public, that is, bidders or their representatives may be present. If requested by any bidder, the names of bidders and if practical the total amount of each bid and of any alternative bids, will be read aloud.
13. The period for which offers are to remain valid and binding is indicated in the bid documents and is calculated from the closing date on the understanding that offers are to remain in force and binding until the close of business on the last day of the period calculated and if this day falls on a Saturday, Sunday or public holiday, the bid is to remain valid and binding until the close of business on the following working day.
14. These conditions (ANNEXURE 7) form part of the bid and failure to comply therewith may invalidate a bid.
15. Bidders are requested to promote local content optimally. Bidders who use locally manufactured components, products, equipment and systems, must complete the Declaration Certificate for Local Production and Content Form (SBD 6.2), if attached.
16. After public opening of bids, information relating to the examination, clarification and evaluation of bids and recommendations concerning awards will not be disclosed to bidders or other persons not officially concerned with the process, until the successful bidder is notified of the award. The bid documentation of bidders is considered to be confidential and will under no circumstances be made available to other bidders or other persons.
17. If you are a supplier but not the actual manufacturer and will be sourcing the product(s) from another company, a letter from that company(ies)/supplier(s) confirming firm supply arrangement(s) in this regard, has to accompany your bid and failure to submit the document may invalidate your bid.
 - 17.1 The said company/supplier must confirm that it has familiarised itself with the item description, specifications and bid conditions and if the bid consist of more than one item it should be clearly indicated in respect of which item(s) the supportive letter has been issued.
18. The financial standing of bidders and their ability to manufacture or to supply goods or to render a service may be examined before their bids are considered for acceptance.
19. The Department may, where a bid relates to more than one item, accept such bid in respect of any specific item or items and also accept part of the specified quantity of any specific item or items.
20. The Department is not obliged to accept any bid. The evaluation of a bid will be done in accordance with the Preferential Procurement Policy Framework Act, 2000 (Act no. 5 of 2000) and its regulations.

ANNEXURE 7

21. After approval of the bid, both parties must sign a written contract. The Contract Form must be filled in duplicate by both the successful bidder and the purchaser. Both Contract Forms must be signed in the original so that the successful bidder and the purchaser would be in possession of originally signed contracts for their respective records.
- 21.1 Failure of the successful bidder to sign the Contract Form in ink may result in the invalidation of their bid.

Special Conditions of Bid: Purchases
November 2011

CERTIFICATE OF INDEPENDENT BID DETERMINATION

SBD 9

- 1 This Standard Bidding Document (SBD) must form part of all bids¹ invited.
- 2 Section 4 (1) (b) (iii) of the Competition Act No. 89 of 1998, as amended, prohibits an agreement between, or concerted practice by, firms, or a decision by an association of firms, if it is between parties in a horizontal relationship and if it involves collusive bidding (or bid rigging).² Collusive bidding is a *pe se* prohibition meaning that it cannot be justified under any grounds.
- 3 Treasury Regulation 16A9 prescribes that accounting officers and accounting authorities must take all reasonable steps to prevent abuse of the supply chain management system and authorizes accounting officers and accounting authorities to:
 - a. disregard the bid of any bidder if that bidder, or any of its directors have abused the institution's supply chain management system and or committed fraud or any other improper conduct in relation to such system.
 - b. cancel a contract awarded to a supplier of goods and services if the supplier committed any corrupt or fraudulent act during the bidding process or the execution of that contract.
- 4 This SBD serves as a certificate of declaration that would be used by institutions to ensure that, when bids are considered, reasonable steps are taken to prevent any form of bid-rigging.
- 5 In order to give effect to the above, the attached Certificate of Bid Determination (SBD 9) must be completed and submitted with the bid:

¹ Includes price quotations, advertised competitive bids, limited bids and proposals.

² Bid rigging (or collusive bidding) occurs when businesses, that would otherwise be expected to compete, secretly conspire to raise prices or lower the quality of goods and / or services for purchasers who wish to acquire goods and / or services through a bidding process. Bid rigging is, therefore, an agreement between competitors not to compete.

CERTIFICATE OF INDEPENDENT BID DETERMINATION

I, the undersigned, in submitting the accompanying bid:

(Bid Number and Description)

in response to the invitation for the bid made by:

(Name of Institution)

do hereby make the following statements that I certify to be true and complete in every respect:

I certify, on behalf of: _____ that:
(Name of Bidder)

1. I have read and I understand the contents of this Certificate;
2. I understand that the accompanying bid will be disqualified if this Certificate is found not to be true and complete in every respect;
3. I am authorized by the bidder to sign this Certificate, and to submit the accompanying bid, on behalf of the bidder;
4. Each person whose signature appears on the accompanying bid has been authorized by the bidder to determine the terms of, and to sign the bid, on behalf of the bidder;
5. For the purposes of this Certificate and the accompanying bid, I understand that the word "competitor" shall include any individual or organization, other than the bidder, whether or not affiliated with the bidder, who:
 - (a) has been requested to submit a bid in response to this bid invitation;
 - (b) could potentially submit a bid in response to this bid invitation, based on their qualifications, abilities or experience; and
 - (c) provides the same goods and services as the bidder and/or is in the same line of business as the bidder

6. The bidder has arrived at the accompanying bid independently from, and without consultation, communication, agreement or arrangement with any competitor. However communication between partners in a joint venture or consortium³ will not be construed as collusive bidding.
7. In particular, without limiting the generality of paragraphs 6 above, there has been no consultation, communication, agreement or arrangement with any competitor regarding:
 - (a) prices;
 - (b) geographical area where product or service will be rendered (market allocation)
 - (c) methods, factors or formulas used to calculate prices;
 - (d) the intention or decision to submit or not to submit, a bid;
 - (e) the submission of a bid which does not meet the specifications and conditions of the bid; or
 - (f) bidding with the intention not to win the bid.
8. In addition, there have been no consultations, communications, agreements or arrangements with any competitor regarding the quality, quantity, specifications and conditions or delivery particulars of the products or services to which this bid invitation relates.
9. The terms of the accompanying bid have not been, and will not be, disclosed by the bidder, directly or indirectly, to any competitor, prior to the date and time of the official bid opening or of the awarding of the contract.

³ Joint venture or Consortium means an association of persons for the purpose of combining their expertise, property, capital, efforts, skill and knowledge in an activity for the execution of a contract.

10. I am aware that, in addition and without prejudice to any other remedy provided to combat any restrictive practices related to bids and contracts, bids that are suspicious will be reported to the Competition Commission for investigation and possible imposition of administrative penalties in terms of section 59 of the Competition Act No 89 of 1998 and or may be reported to the National Prosecuting Authority (NPA) for criminal investigation and or may be restricted from conducting business with the public sector for a period not exceeding ten (10) years in terms of the Prevention and Combating of Corrupt Activities Act No 12 of 2004 or any other applicable legislation.

.....
Signature

.....
Date

.....
Position

.....
Name of Bidder

November 11

DEPARTMENT WATER AFFAIRS

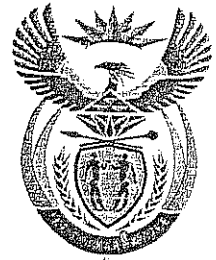

1. VENDOR MASTER REGISTRATION AND MAINTENANCE

1.1 Supplier detail verification:

National Treasury has implemented an electronic verification system (Safety Web) to verify the banking details of all Vendors with the Commercial Banks.

This means that the Vendor details for verification must be exactly the same as the record of the Banks, e.g.:

a.) Individuals:

Details should not be recorded as "trading as", but as per the records of the particular Bank (*If the name of a vendor with the Bank is in a certain language, capture as it is with the Bank*);

ID number is a compulsory field for individuals (*The Banks do verify the ID number and reject the supplier details if this information is not included or incorrect*).

b.) Close Corporations:

The name must end with CC or BK;

Registration number ends with 23;

If verified details requires a CK in front or the back of the company registration number, e.g. CK1999/123456/23 or 1999/123456/23 CK it should be captured as such.

Estate Late: Must have an ID number (If the account was not closed and a new account opened in Estate Late it will be the same as if the account was opened when the person was still alive.

Attorneys / Doctors ID number (For individuals) or Company registration number (If registered as a CC).

c.) Companies:

Company registration details have to be captured with the slash (e.g. 1195/012564/07); Use the table below as guideline.

Type of Entity	Company registration number	Wording that should appear in the name
Close Corporation	2000 / 000000 / 23	CC/BK
Private Company	2000 / 000000 / 07	Pty Ltd / Edms Bpk / Eiendoms Beperk / Proprietary Limited / Pty Limited / Proprietary Ltd / Edms Beperk / Eiendoms Bpk
Public Company	2000 / 000000 / 06	Ltd / Bpk / Beperk / Limited
Trust	ITOO/ 00	Not all Trusts have registration numbers and in such a case the ID number must be used.
Incorporated under Section 21	2000 / 000000 / 08	
Incorporated	2000 / 000000 / 21	Inc. ling

Before any details can be captured on Safetyweb, by Head Office for verification, the Vendor must provide the department with the banking details as captured and recorded with their banker. These details must be verified by the Bank against the following screens:

- i. **FNB** - information must be according to the HOGAN System on the CIS4
- ii. **NEDBANK** - Banking Platform under the Client Details Tab
- iii. **ABSA** - information as captured on the CIF screen
- iv. **Standard Bank** - information as per look-up-screen

Please note that the Banks will not provide these screens to the Vendor / Department but will merely validate the Vendor's details against these screens.

1.2 Capturing of Vendor details:

Herewith some standard rules to comply with when capturing Vendor details:

- i. Do not leave spaces and use only numeric characters in the account number field.
- ii. Under no circumstances use the details on the cheque for verification of the name. Departments must verify the registered name of the company at the Bank.

1.3

Vendor master maintenance form:

The attached Vendor Master Maintenance form must be completed by Vendors, Contractors and all Departmental staff that will be incorporated into the Trading Account.

No alterations to the form will be accepted, and the form should not be scanned and e-mailed.

Section A:

To be completed by the relevant Department Water Affairs Office.

Sections B, C, D and E:

The Vendor must complete all the required fields.

Section F:

The Vendor must complete all required fields. Take note that the section must be fully signed (initials and surname as well as signature) by the Vendor as well as the Bank Official (including bank stamp).

General:

Please note that each SAP Vendor Master form must be supported by **copies** of one of the following documentation:

Persal – Printout of function 4.3.1 (Enquiry: Specific Personal Particulars);

Individual – ID document;

Company – Tax Clearance certificate or CK1 or SARS notice of registration or Tax invoice with printed VAT-number. If not register for VAT an ID document of owner and signed declaration that the company is not registered for VAT.

Please ensure that all the fields are completed and that the information is clearly readable.

1.4

Payment terms:

The payment term defines the terms of cash discount percentages and payment methods.

The Vendor should indicate, in the space provided on the Vendor Master Maintenance Form what their payment terms are, e.g.:

Z007	Payable immediately Due net
Z001	Within 30 days Due net
Z010	Within 30 days 1.5% Discount
Z011	Within 30 days 2% Discount
Z012	Within 30 days 2.5% Discount

Other payment terms will be applied on an ad-hoc basis, but it is the responsibility of the relevant Regional Office / Construction Scheme to negotiate / inform their Vendors of this decision.

1.5

Contact persons:

All completed Vendor Master Maintenance Forms must be returned to the relevant Department Water Affairs Office.



dwa

Department: Water Affairs
REPUBLIC OF SOUTH AFRICA

VENDOR MASTER MAINTENANCE



Version 2
03-Dec-07

OFFICE USE ONLY

Created by

Authorised by

Date created
d d m m y y

Date authorised
d d m m y y

Section A: Office (DWAF) Requesting Vendor Master (For official use only)

Indicate with an X New Vendor Information

Update Vendor Information

Office

Official's Initials and Surname

Official's Signature

Telephone

Fax No.

OFFICE DATE STAMP

Section B: Personal Detail of Vendor

Registered Name of Vendor

SARS Office (if applicable)

Trade Name

VAT Number

Payment Term

Title if Applicable

Section C: Address of Vendor

Postal Address

Street Address

Postal Code

Postal Code

Section D: Telephone / Fax Numbers (Vendor Contact Details)

Contact Person (Vendor)

E-mail

Telephone Number - Area Code with Number

Fax Number

Mobile number

Preferred method of communication (Please select only one)

Facsimile E-mail Post

Section E: Vendor detail

Supplier Type: Individual Department Partnership
 Company Trust
 CC Other (Specify)

Supporting documentation must accompany this form

VENDOR MASTER MAINTENANCE (CONTINUATION PAGE)

Section F - Vendor's Bank Details

I/We hereby request and authorise you to pay any amounts, which may accrue to me/us to the credit of my/our account with the mentioned bank.

I/We understand that the credit transfers hereby authorised will be processed by computer through a system known as the "ACB ELECTRONIC FUND TRANSFER SERVICE", and I/we also understand that no additional advice of payment will be provided by my/our bank, but details of each payment will be printed on my/our bank statement or any accompanying voucher. (This does not apply where it is not customary for banks to furnish bank statements)

I/We understand that the Department will supply a payment advice in the normal manner, and that it will indicate the date on which the funds will be made available in my/our account.

This authority may be cancelled by me/us by giving thirty (30) days notice by prepaid registered post.

Please ensure the information is validate as per required bank screens

I/We understand that bank details provided should be exactly as per the records held by the bank.

I/We understand that the Department will not assume responsibility for any delayed payments, as a result of incorrect information supplied.

Initials and Surname of Vendor

Authorised Signature of Vendor

d d m m y y

Registered Name of Account Holder

Bank Name

Branch Name

Branch Code

Account Number

* ID Number

Passport Number

** Company Registration Number

*** CC / CK Registration Number

Practice Number

* Compulsory for individuals

** Compulsory for Companies

*** Compulsory where applicable

Type of Account - Indicate with X	
<input type="checkbox"/>	1 Cheque Account
<input type="checkbox"/>	2 Savings Account
<input type="checkbox"/>	3 Transmission Account

It is hereby confirmed that this details have been verified against the following screens:

- ABSA - CIF Screen
- FNB - Hogans System on the CIS4
- STD Bank - Look - Up - Screen
- Nedbank - Banking Platform under the Client Details Tab

DATE STAMP OF BANK - CERTIFIED AS CORRECT

Initials and Surname (Bank Official) who verified information against the relevant Bank Screen

Bank Branch and Town/City where information has been verified

d d m m y y

Signature (Bank Official) who verified information

Telephone Number of Bank who verified information

DEPARTMENT OF WATER AND SANITATION

BID W 1021(WTE)

THE SUPPLY AND DELIVERY OF 184 DIFFERENT FLANGES FULLY MACHINED, DRILLED AND NORMALISED AS
PER SUPPLIED DRAWINGS FOR CONSTRUCTION CENTRAL

SECTION 2: CONDITIONS OF CONTRACT

CONTENTS

- A. GENERAL CONDITIONS OF CONTRACT
- B. SPECIAL CONDITIONS OF CONTRACT

CONDITIONS OF CONTRACT

A. GENERAL CONDITIONS OF CONTRACT

The Contract shall be governed by: "General Conditions of Contract", which is attached to this bid document. The only variations from these General Conditions of Contract shall be given in the Special conditions of Contract below.

B. SPECIAL CONDITIONS OF CONTRACT

This section must be completed in full failure to do so may invalidate your bid

***Delete which are not applicable**

1. Is the offer strictly in accordance with the conditions and specifications? *YES / NO
If not in accordance with the specification, furnish the deviations. _____
2. Period required for commencement with service after receipt of order. _____
3. Are you registered in terms of section 23(1) or 23(3) of the value Added Tax Act, 1991 (Act no 89 of 1991)? *YES / NO
If so, state your VAT registration number. _____
4. Is the bid price firm for the duration of the contract period? *YES / NO
5. **The Department of Water and Sanitation will not entertain any claims for non-firm price increases claimed at a later date, unless such non-firm price adjustments are clearly motivated. No exception will be made in this regard.** TAKE NOTE
6. **Penalties and delay damages**
The penalties referred to in clause 22 of the General Conditions of Contract shall comprise of delay damages of R4 000 per day TAKE NOTE
The maximum amount of delay damages shall be 10% of the final Contract Price, excluding delay damages. TAKE NOTE
7. The evaluation Committee will be following a phased approach during the evaluation.

Phase 1

Administrative Compliance:

Bidders are required to submit and or complete the following documents which should form part of the bid submitted by closing date. Omission to complete and/or submit the listed documents will render your bid non responsive and the bid will not be considered for the phase 2 evaluation. TAKE NOTE

- (a) An original and valid tax clearance certificate
- (b) The pricing schedule (SBD3.2)
- (c) Completion and inclusion of standard bidding documents. (SBD1, SBD4, SBD6.1, SBD8, SBD9)
- (d) Proof of compliance certificate of SANS 1123 mild steel grade 350 WA or equivalent or issued by other countries.
- (e) Compulsory briefing session should be attended (Signing of attendance register.)

Phase 2

Technical Compliance:

The bid will be evaluated using the criteria below and failure to comply with **all** the specifications as listed will render your bid as not to specification and non responsive and the bid will not be considered for the phase 3 evaluation.

- (a) Standard Specifications as set out under Section 3: Specifications and the compliance thereof
- (b) The bid will be rendered non responsive if the bidder fails to complete the "Comply / Not Comply" in the Specification under Section 3: Specifications

Phase 3

Evaluation of price and preference points claimed:

During this phase, bid proposals that passed the phase two will be further evaluated based on the 90/10 preference points system in accordance with the PPPFA Act, where 90 points will be attained in respect of price and 10 points will be awarded to a bidder for attaining the B-BBEE Status Level of Contributor in accordance with the table below:

B-BBEE Status Level of Contributor	Number of points (90/10 system)
1	10
2	9
3	8
4	5
5	4
6	3
7	2
8	1
Non-compliant contributor	0

TAKE NOTE

In order to claim the B-BBEE Status Level of Contributor points, bidders must submit original and valid B-BBEE Status Level Verification Certificates or certified copies thereof, issued by accredited Verification Agency/s by SANAS or 11.2.3.2 Registered Auditor approved by Independent Regulatory Board of Auditor (IRBA), together with their bids to substantiate their B-BBEE rating claims. The Exempted Micro Enterprise must submit a letter from the Accounting Officer who is appointed in terms of Close Corporation Act.

Bidders who do not submit B-BBEE Status Level Verification Certificates or are non-compliant contributors to B-BBEE do not qualify for preference points for B-BBEE but will not be disqualified from the bidding process. They will score points out of 90 for price only and zero (0) points out of 10 for B-BBEE.

Bidders are requested to complete the preference claim form in order to claim preference points. The points scored by a bidder in respect of points indicated above will be added to the points scored for price.

The highest ranked bidder will be awarded the bid. It should be noted also that the Department reserve the right not to appoint any service provider.

A person will not be awarded points for B-BBEE status level if it is indicated in the bid documents that such bidder intends sub-contracting more than 25% of the value of the contract to any other enterprise that does not qualify for, unless the intended sub-contractor is an EME that has the capability and ability to execute the sub-contract.

A person awarded a contract may not sub-contract more than 25% of the value of the contract to any other enterprise that does not have an equal or higher B-BBEE status level than the person concerned, unless the contract is sub-contracted to an EME that has the capability to execute the sub-contract.

8. In the case where a potential successful bidder are a only a supplier but not the actual manufacturer and will procure the products from a manufacturer or another supplier and did not submit a letter from that manufacturer/supplier confirming firm supply arrangement(s) in this regard by the closing time of this bid, such a letter must be submitted within **14 days** after the receipt of a **"Letter of Notification to Bidder"** from this Department. Failure to comply with this requirement **within 14 calendar** days shall result n the bid being awarded to another bidder.

TAKE NOTE

THE NATIONAL TREASURY

Republic of South Africa

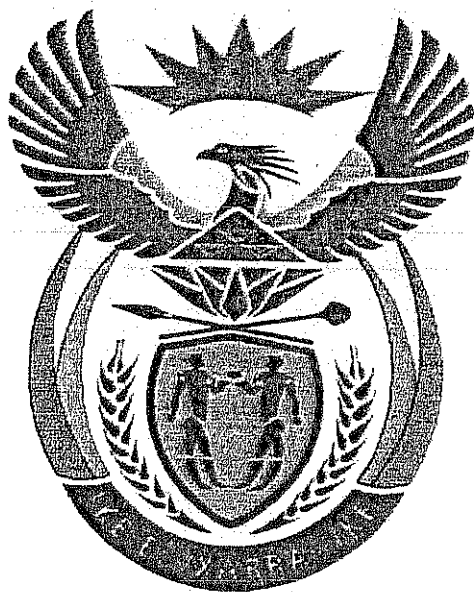

**GOVERNMENT PROCUREMENT:
GENERAL CONDITIONS OF CONTRACT**

July 2010

GOVERNMENT PROCUREMENT
GENERAL CONDITIONS OF CONTRACT
July 2010

NOTES

The purpose of this document is to:

- (i) Draw special attention to certain general conditions applicable to government bids, contracts and orders; and
- (ii) To ensure that clients be familiar with regard to the rights and obligations of all parties involved in doing business with government.

In this document words in the singular also mean in the plural and vice versa and words in the masculine also mean in the feminine and neuter.

- The General Conditions of Contract will form part of all bid documents and may not be amended.
- Special Conditions of Contract (SCC) relevant to a specific bid, should be compiled separately for every bid (if applicable) and will supplement the General Conditions of Contract. Whenever there is a conflict, the provisions in the SCC shall prevail.

TABLE OF CLAUSES

1. Definitions
2. Application
3. General
4. Standards
5. Use of contract documents and information; inspection
6. Patent rights
7. Performance security
8. Inspections, tests and analysis
9. Packing
10. Delivery and documents
11. Insurance
12. Transportation
13. Incidental services
14. Spare parts
15. Warranty
16. Payment
17. Prices
18. Contract amendments
19. Assignment
20. Subcontracts
21. Delays in the supplier's performance
22. Penalties
23. Termination for default
24. Dumping and countervailing duties
25. Force Majeure
26. Termination for insolvency
27. Settlement of disputes
28. Limitation of liability
29. Governing language
30. Applicable law
31. Notices
32. Taxes and duties
33. National Industrial Participation Programme (NIPP)
34. Prohibition of restrictive practices

General Conditions of Contract

I. Definitions

1. The following terms shall be interpreted as indicated:
 - 1.1 "Closing time" means the date and hour specified in the bidding documents for the receipt of bids.
 - 1.2 "Contract" means the written agreement entered into between the purchaser and the supplier, as recorded in the contract form signed by the parties, including all attachments and appendices thereto and all documents incorporated by reference therein.
 - 1.3 "Contract price" means the price payable to the supplier under the contract for the full and proper performance of his contractual obligations.
 - 1.4 "Corrupt practice" means the offering, giving, receiving, or soliciting of any thing of value to influence the action of a public official in the procurement process or in contract execution.
 - 1.5 "Countervailing duties" are imposed in cases where an enterprise abroad is subsidized by its government and encouraged to market its products internationally.
 - 1.6 "Country of origin" means the place where the goods were mined, grown or produced or from which the services are supplied. Goods are produced when, through manufacturing, processing or substantial and major assembly of components, a commercially recognized new product results that is substantially different in basic characteristics or in purpose or utility from its components.
 - 1.7 "Day" means calendar day.
 - 1.8 "Delivery" means delivery in compliance of the conditions of the contract or order.
 - 1.9 "Delivery ex stock" means immediate delivery directly from stock actually on hand.
 - 1.10 "Delivery into consignees store or to his site" means delivered and unloaded in the specified store or depot or on the specified site in compliance with the conditions of the contract or order, the supplier bearing all risks and charges involved until the supplies are so delivered and a valid receipt is obtained.
 - 1.11 "Dumping" occurs when a private enterprise abroad market its goods on own initiative in the RSA at lower prices than that of the country of origin and which have the potential to harm the local industries in the

RSA.

- 1.12 "Force majeure" means an event beyond the control of the supplier and not involving the supplier's fault or negligence and not foreseeable. Such events may include, but is not restricted to, acts of the purchaser in its sovereign capacity, wars or revolutions, fires, floods, epidemics, quarantine restrictions and freight embargoes.
- 1.13 "Fraudulent practice" means a misrepresentation of facts in order to influence a procurement process or the execution of a contract to the detriment of any bidder, and includes collusive practice among bidders (prior to or after bid submission) designed to establish bid prices at artificial non-competitive levels and to deprive the bidder of the benefits of free and open competition.
- 1.14 "GCC" means the General Conditions of Contract.
- 1.15 "Goods" means all of the equipment, machinery, and/or other materials that the supplier is required to supply to the purchaser under the contract.
- 1.16 "Imported content" means that portion of the bidding price represented by the cost of components, parts or materials which have been or are still to be imported (whether by the supplier or his subcontractors) and which costs are inclusive of the costs abroad, plus freight and other direct importation costs such as landing costs, dock dues, import duty, sales duty or other similar tax or duty at the South African place of entry as well as transportation and handling charges to the factory in the Republic where the supplies covered by the bid will be manufactured.
- 1.17 "Local content" means that portion of the bidding price which is not included in the imported content provided that local manufacture does take place.
- 1.18 "Manufacture" means the production of products in a factory using labour, materials, components and machinery and includes other related value-adding activities.
- 1.19 "Order" means an official written order issued for the supply of goods or works or the rendering of a service.
- 1.20 "Project site," where applicable, means the place indicated in bidding documents.
- 1.21 "Purchaser" means the organization purchasing the goods.
- 1.22 "Republic" means the Republic of South Africa.
- 1.23 "SCC" means the Special Conditions of Contract.
- 1.24 "Services" means those functional services ancillary to the supply of the goods, such as transportation and any other incidental services, such as installation, commissioning, provision of technical assistance, training, catering, gardening, security, maintenance and other such

obligations of the supplier covered under the contract.

- 1.25 "Written" or "in writing" means handwritten in ink or any form of electronic or mechanical writing.
- 2. Application**
- 2.1 These general conditions are applicable to all bids, contracts and orders including bids for functional and professional services, sales, hiring, letting and the granting or acquiring of rights, but excluding immovable property, unless otherwise indicated in the bidding documents.
- 2.2 Where applicable, special conditions of contract are also laid down to cover specific supplies, services or works.
- 2.3 Where such special conditions of contract are in conflict with these general conditions, the special conditions shall apply.
- 3. General**
- 3.1 Unless otherwise indicated in the bidding documents, the purchaser shall not be liable for any expense incurred in the preparation and submission of a bid. Where applicable a non-refundable fee for documents may be charged.
- 3.2 With certain exceptions, invitations to bid are only published in the Government Tender Bulletin. The Government Tender Bulletin may be obtained directly from the Government Printer, Private Bag X85, Pretoria 0001, or accessed electronically from www.treasury.gov.za
- 4. Standards**
- 4.1 The goods supplied shall conform to the standards mentioned in the bidding documents and specifications.
- 5. Use of contract documents and information; inspection.**
- 5.1 The supplier shall not, without the purchaser's prior written consent, disclose the contract, or any provision thereof, or any specification, plan, drawing, pattern, sample, or information furnished by or on behalf of the purchaser in connection therewith, to any person other than a person employed by the supplier in the performance of the contract. Disclosure to any such employed person shall be made in confidence and shall extend only so far as may be necessary for purposes of such performance.
- 5.2 The supplier shall not, without the purchaser's prior written consent, make use of any document or information mentioned in GCC clause 5.1 except for purposes of performing the contract.
- 5.3 Any document, other than the contract itself mentioned in GCC clause 5.1 shall remain the property of the purchaser and shall be returned (all copies) to the purchaser on completion of the supplier's performance under the contract if so required by the purchaser.
- 5.4 The supplier shall permit the purchaser to inspect the supplier's records relating to the performance of the supplier and to have them audited by auditors appointed by the purchaser, if so required by the purchaser.
- 6. Patent rights**
- 6.1 The supplier shall indemnify the purchaser against all third-party claims of infringement of patent, trademark, or industrial design rights arising from use of the goods or any part thereof by the purchaser.

7. Performance security

- 7.1 Within thirty (30) days of receipt of the notification of contract award, the successful bidder shall furnish to the purchaser the performance security of the amount specified in SCC.
- 7.2 The proceeds of the performance security shall be payable to the purchaser as compensation for any loss resulting from the supplier's failure to complete his obligations under the contract.
- 7.3 The performance security shall be denominated in the currency of the contract, or in a freely convertible currency acceptable to the purchaser and shall be in one of the following forms:
 - (a) a bank guarantee or an irrevocable letter of credit issued by a reputable bank located in the purchaser's country or abroad, acceptable to the purchaser, in the form provided in the bidding documents or another form acceptable to the purchaser; or
 - (b) a cashier's or certified cheque
- 7.4 The performance security will be discharged by the purchaser and returned to the supplier not later than thirty (30) days following the date of completion of the supplier's performance obligations under the contract, including any warranty obligations, unless otherwise specified in SCC.

8. Inspections, tests and analyses

- 8.1 All pre-bidding testing will be for the account of the bidder.
- 8.2 If it is a bid condition that supplies to be produced or services to be rendered should at any stage during production or execution or on completion be subject to inspection, the premises of the bidder or contractor shall be open, at all reasonable hours, for inspection by a representative of the Department or an organization acting on behalf of the Department.
- 8.3 If there are no inspection requirements indicated in the bidding documents and no mention is made in the contract, but during the contract period it is decided that inspections shall be carried out, the purchaser shall itself make the necessary arrangements, including payment arrangements with the testing authority concerned.
- 8.4 If the inspections, tests and analyses referred to in clauses 8.2 and 8.3 show the supplies to be in accordance with the contract requirements, the cost of the inspections, tests and analyses shall be defrayed by the purchaser.
- 8.5 Where the supplies or services referred to in clauses 8.2 and 8.3 do not comply with the contract requirements, irrespective of whether such supplies or services are accepted or not, the cost in connection with these inspections, tests or analyses shall be defrayed by the supplier.
- 8.6 Supplies and services which are referred to in clauses 8.2 and 8.3 and which do not comply with the contract requirements may be rejected.
- 8.7 Any contract supplies may on or after delivery be inspected, tested or

analyzed and may be rejected if found not to comply with the requirements of the contract. Such rejected supplies shall be held at the cost and risk of the supplier who shall, when called upon, remove them immediately at his own cost and forthwith substitute them with supplies which do comply with the requirements of the contract. Failing such removal the rejected supplies shall be returned at the suppliers cost and risk. Should the supplier fail to provide the substitute supplies forthwith, the purchaser may, without giving the supplier further opportunity to substitute the rejected supplies, purchase such supplies as may be necessary at the expense of the supplier.

8.8 The provisions of clauses 8.4 to 8.7 shall not prejudice the right of the purchaser to cancel the contract on account of a breach of the conditions thereof, or to act in terms of Clause 23 of GCC.

8. Packing

9.1 The supplier shall provide such packing of the goods as is required to prevent their damage or deterioration during transit to their final destination, as indicated in the contract. The packing shall be sufficient to withstand, without limitation, rough handling during transit and exposure to extreme temperatures, salt and precipitation during transit, and open storage. Packing, case size and weights shall take into consideration, where appropriate, the remoteness of the goods' final destination and the absence of heavy handling facilities at all points in transit.

9.2 The packing, marking, and documentation within and outside the packages shall comply strictly with such special requirements as shall be expressly provided for in the contract, including additional requirements, if any, specified in SCC, and in any subsequent instructions ordered by the purchaser.

10. Delivery and documents

10.1 Delivery of the goods shall be made by the supplier in accordance with the terms specified in the contract. The details of shipping and/or other documents to be furnished by the supplier are specified in SCC.

10.2 Documents to be submitted by the supplier are specified in SCC.

11. Insurance

11.1 The goods supplied under the contract shall be fully insured in a freely convertible currency against loss or damage incidental to manufacture or acquisition, transportation, storage and delivery in the manner specified in the SCC.

12. Transportation

12.1 Should a price other than an all-inclusive delivered price be required, this shall be specified in the SCC.

13. Incidental services

13.1 The supplier may be required to provide any or all of the following services, including additional services, if any, specified in SCC:

- (a) performance or supervision of on-site assembly and/or commissioning of the supplied goods;
- (b) furnishing of tools required for assembly and/or maintenance of the supplied goods;
- (c) furnishing of a detailed operations and maintenance manual for each appropriate unit of the supplied goods;

- (d) performance or supervision or maintenance and/or repair of the supplied goods, for a period of time agreed by the parties, provided that this service shall not relieve the supplier of any warranty obligations under this contract; and
- (e) training of the purchaser's personnel, at the supplier's plant and/or on-site, in assembly, start-up, operation, maintenance, and/or repair of the supplied goods.

13.2 Prices charged by the supplier for incidental services, if not included in the contract price for the goods, shall be agreed upon in advance by the parties and shall not exceed the prevailing rates charged to other parties by the supplier for similar services.

14. Spare parts

14.1 As specified in SCC, the supplier may be required to provide any or all of the following materials, notifications, and information pertaining to spare parts manufactured or distributed by the supplier:

- (a) such spare parts as the purchaser may elect to purchase from the supplier, provided that this election shall not relieve the supplier of any warranty obligations under the contract; and
- (b) in the event of termination of production of the spare parts:
 - (i) Advance notification to the purchaser of the pending termination, in sufficient time to permit the purchaser to procure needed requirements; and
 - (ii) following such termination, furnishing at no cost to the purchaser, the blueprints, drawings, and specifications of the spare parts, if requested.

15. Warranty

15.1 The supplier warrants that the goods supplied under the contract are new, unused, of the most recent or current models, and that they incorporate all recent improvements in design and materials unless provided otherwise in the contract. The supplier further warrants that all goods supplied under this contract shall have no defect, arising from design, materials, or workmanship (except when the design and/or material is required by the purchaser's specifications) or from any act or omission of the supplier, that may develop under normal use of the supplied goods in the conditions prevailing in the country of final destination.

15.2 This warranty shall remain valid for twelve (12) months after the goods, or any portion thereof as the case may be, have been delivered to and accepted at the final destination indicated in the contract, or for eighteen (18) months after the date of shipment from the port or place of loading in the source country, whichever period concludes earlier, unless specified otherwise in SCC.

15.3 The purchaser shall promptly notify the supplier in writing of any claims arising under this warranty.

15.4 Upon receipt of such notice, the supplier shall, within the period specified in SCC and with all reasonable speed, repair or replace the defective goods or parts thereof, without costs to the purchaser.

15.5 If the supplier, having been notified, fails to remedy the defect(s) within the period specified in SCC, the purchaser may proceed to take

such remedial action as may be necessary, at the supplier's risk and expense and without prejudice to any other rights which the purchaser may have against the supplier under the contract.

16. Payment

16.1 The method and conditions of payment to be made to the supplier under this contract shall be specified in SCC.

16.2 The supplier shall furnish the purchaser with an invoice accompanied by a copy of the delivery note and upon fulfillment of other obligations stipulated in the contract.

16.3 Payments shall be made promptly by the purchaser, but in no case later than thirty (30) days after submission of an invoice or claim by the supplier.

16.4 Payment will be made in Rand unless otherwise stipulated in SCC.

17. Prices

17.1 Prices charged by the supplier for goods delivered and services performed under the contract shall not vary from the prices quoted by the supplier in his bid, with the exception of any price adjustments authorized in SCC or in the purchaser's request for bid validity extension, as the case may be.

18. Contract amendments

18.1 No variation in or modification of the terms of the contract shall be made except by written amendment signed by the parties concerned.

19. Assignment

19.1 The supplier shall not assign, in whole or in part, its obligations to perform under the contract, except with the purchaser's prior written consent.

20. Subcontracts

20.1 The supplier shall notify the purchaser in writing of all subcontracts awarded under this contracts if not already specified in the bid. Such notification, in the original bid or later, shall not relieve the supplier from any liability or obligation under the contract.

21. Delays in the supplier's performance

21.1 Delivery of the goods and performance of services shall be made by the supplier in accordance with the time schedule prescribed by the purchaser in the contract.

21.2 If at any time during performance of the contract, the supplier or its subcontractor(s) should encounter conditions impeding timely delivery of the goods and performance of services, the supplier shall promptly notify the purchaser in writing of the fact of the delay, its likely duration and its cause(s). As soon as practicable after receipt of the supplier's notice, the purchaser shall evaluate the situation and may at his discretion extend the supplier's time for performance, with or without the imposition of penalties, in which case the extension shall be ratified by the parties by amendment of contract.

21.3 No provision in a contract shall be deemed to prohibit the obtaining of supplies or services from a national department, provincial department, or a local authority.

21.4 The right is reserved to procure outside of the contract small quantities or to have minor essential services executed if an emergency arises, the

supplier's point of supply is not situated at or near the place where the supplies are required, or the supplier's services are not readily available.

21.5 Except as provided under GCC Clause 25, a delay by the supplier in the performance of its delivery obligations shall render the supplier liable to the imposition of penalties, pursuant to GCC Clause 22, unless an extension of time is agreed upon pursuant to GCC Clause 21.2 without the application of penalties.

21.6 Upon any delay beyond the delivery period in the case of a supplies contract, the purchaser shall, without canceling the contract, be entitled to purchase supplies of a similar quality and up to the same quantity in substitution of the goods not supplied in conformity with the contract and to return any goods delivered later at the supplier's expense and risk, or to cancel the contract and buy such goods as may be required to complete the contract and without prejudice to his other rights, be entitled to claim damages from the supplier.

22. Penalties

22.1 Subject to GCC Clause 25, if the supplier fails to deliver any or all of the goods or to perform the services within the period(s) specified in the contract, the purchaser shall, without prejudice to its other remedies under the contract, deduct from the contract price, as a penalty, a sum calculated on the delivered price of the delayed goods or unperformed services using the current prime interest rate calculated for each day of the delay until actual delivery or performance. The purchaser may also consider termination of the contract pursuant to GCC Clause 23.

23. Termination for default

23.1 The purchaser, without prejudice to any other remedy for breach of contract, by written notice of default sent to the supplier, may terminate this contract in whole or in part:

- (a) if the supplier fails to deliver any or all of the goods within the period(s) specified in the contract, or within any extension thereof granted by the purchaser pursuant to GCC Clause 21.2;
- (b) if the Supplier fails to perform any other obligation(s) under the contract; or
- (c) if the supplier, in the judgment of the purchaser, has engaged in corrupt or fraudulent practices in competing for or in executing the contract.

23.2 In the event the purchaser terminates the contract in whole or in part, the purchaser may procure, upon such terms and in such manner as it deems appropriate, goods, works or services similar to those undelivered, and the supplier shall be liable to the purchaser for any excess costs for such similar goods, works or services. However, the supplier shall continue performance of the contract to the extent not terminated.

23.3 Where the purchaser terminates the contract in whole or in part, the purchaser may decide to impose a restriction penalty on the supplier by prohibiting such supplier from doing business with the public sector for a period not exceeding 10 years.

23.4 If a purchaser intends imposing a restriction on a supplier or any

person associated with the supplier, the supplier will be allowed a time period of not more than fourteen (14) days to provide reasons why the envisaged restriction should not be imposed. Should the supplier fail to respond within the stipulated fourteen (14) days the purchaser may regard the intended penalty as not objected against and may impose it on the supplier.

23.5 Any restriction imposed on any person by the Accounting Officer / Authority will, at the discretion of the Accounting Officer / Authority, also be applicable to any other enterprise or any partner, manager, director or other person who wholly or partly exercises or exercised or may exercise control over the enterprise of the first-mentioned person, and with which enterprise or person the first-mentioned person, is or was in the opinion of the Accounting Officer / Authority actively associated.

23.6 If a restriction is imposed, the purchaser must, within five (5) working days of such imposition, furnish the National Treasury, with the following information:

- (i) the name and address of the supplier and / or person restricted by the purchaser;
- (ii) the date of commencement of the restriction
- (iii) the period of restriction; and
- (iv) the reasons for the restriction.

These details will be loaded in the National Treasury's central database of suppliers or persons prohibited from doing business with the public sector.

23.7 If a court of law convicts a person of an offence as contemplated in sections 12 or 13 of the Prevention and Combating of Corrupt Activities Act, No. 12 of 2004, the court may also rule that such person's name be endorsed on the Register for Tender Defaulters. When a person's name has been endorsed on the Register, the person will be prohibited from doing business with the public sector for a period not less than five years and not more than 10 years. The National Treasury is empowered to determine the period of restriction and each case will be dealt with on its own merits. According to section 32 of the Act the Register must be open to the public. The Register can be perused on the National Treasury website.

24. Anti-dumping and countervailing duties and rights

24.1 When, after the date of bid, provisional payments are required, or anti-dumping or countervailing duties are imposed, or the amount of a provisional payment or anti-dumping or countervailing right is increased in respect of any dumped or subsidized import, the State is not liable for any amount so required or imposed, or for the amount of any such increase. When, after the said date, such a provisional payment is no longer required or any such anti-dumping or countervailing right is abolished, or where the amount of such provisional payment or any such right is reduced, any such favourable difference shall on demand be paid forthwith by the contractor to the State or the State may deduct such amounts from moneys (if any) which may otherwise be due to the contractor in regard to supplies or services which he delivered or rendered, or is to deliver or render in terms of the contract or any other contract or any other amount which

may be due to him

25. Force Majeure

25.1 Notwithstanding the provisions of GCC Clauses 22 and 23, the supplier shall not be liable for forfeiture of its performance security, damages, or termination for default if and to the extent that his delay in performance or other failure to perform his obligations under the contract is the result of an event of force majeure.

25.2 If a force majeure situation arises, the supplier shall promptly notify the purchaser in writing of such condition and the cause thereof. Unless otherwise directed by the purchaser in writing, the supplier shall continue to perform its obligations under the contract as far as is reasonably practical, and shall seek all reasonable alternative means for performance not prevented by the force majeure event.

26. Termination for insolvency

26.1 The purchaser may at any time terminate the contract by giving written notice to the supplier if the supplier becomes bankrupt or otherwise insolvent. In this event, termination will be without compensation to the supplier, provided that such termination will not prejudice or affect any right of action or remedy which has accrued or will accrue thereafter to the purchaser.

27. Settlement of Disputes

27.1 If any dispute or difference of any kind whatsoever arises between the purchaser and the supplier in connection with or arising out of the contract, the parties shall make every effort to resolve amicably such dispute or difference by mutual consultation.

27.2 If, after thirty (30) days, the parties have failed to resolve their dispute or difference by such mutual consultation, then either the purchaser or the supplier may give notice to the other party of his intention to commence with mediation. No mediation in respect of this matter may be commenced unless such notice is given to the other party.

27.3 Should it not be possible to settle a dispute by means of mediation, it may be settled in a South African court of law.

27.4 Mediation proceedings shall be conducted in accordance with the rules of procedure specified in the SCC.

27.5 Notwithstanding any reference to mediation and/or court proceedings herein,

- (a) the parties shall continue to perform their respective obligations under the contract unless they otherwise agree; and
- (b) the purchaser shall pay the supplier any monies due the supplier.

28. Limitation of liability

28.1 Except in cases of criminal negligence or willful misconduct, and in the case of infringement pursuant to Clause 6;

- (a) the supplier shall not be liable to the purchaser, whether in contract, tort, or otherwise, for any indirect or consequential loss or damage, loss of use, loss of production, or loss of profits or interest costs, provided that this exclusion shall not apply to any obligation of the supplier to pay penalties and/or damages to the purchaser; and

- (b) the aggregate liability of the supplier to the purchaser, whether under the contract, in tort or otherwise, shall not exceed the total contract price, provided that this limitation shall not apply to the cost of repairing or replacing defective equipment.
- 29. Governing language
 - 29.1 The contract shall be written in English. All correspondence and other documents pertaining to the contract that is exchanged by the parties shall also be written in English.
- 30. Applicable law
 - 30.1 The contract shall be interpreted in accordance with South African laws, unless otherwise specified in SCC.
- 31. Notices
 - 31.1 Every written acceptance of a bid shall be posted to the supplier concerned by registered or certified mail and any other notice to him shall be posted by ordinary mail to the address furnished in his bid or to the address notified later by him in writing and such posting shall be deemed to be proper service of such notice
 - 31.2 The time mentioned in the contract documents for performing any act after such aforesaid notice has been given, shall be reckoned from the date of posting of such notice.
- 32. Taxes and duties
 - 32.1 A foreign supplier shall be entirely responsible for all taxes, stamp duties, license fees, and other such levies imposed outside the purchaser's country.
 - 32.2 A local supplier shall be entirely responsible for all taxes, duties, license fees, etc., incurred until delivery of the contracted goods to the purchaser.
 - 32.3 No contract shall be concluded with any bidder whose tax matters are not in order. Prior to the award of a bid the Department must be in possession of a tax clearance certificate, submitted by the bidder. This certificate must be an original issued by the South African Revenue Services.
- 33. National Industrial Participation Programme (NIP)
 - 33.1 The NIP Programme administered by the Department of Trade and Industry shall be applicable to all contracts that are subject to the NIP obligation.
- 34. Prohibition of Restrictive practices
 - 34.1 In terms of section 4 (1) (b) (iii) of the Competition Act No. 89 of 1998, as amended, an agreement between, or concerted practice by, firms, or a decision by an association of firms, is prohibited if it is between parties in a horizontal relationship and if a bidder (s) is / are or a contractor(s) was / were involved in collusive bidding (or bid rigging).
 - 34.2 If a bidder(s) or contractor(s), based on reasonable grounds or evidence obtained by the purchaser, has / have engaged in the restrictive practice referred to above, the purchaser may refer the matter to the Competition Commission for investigation and possible imposition of administrative penalties as contemplated in the Competition Act No. 89 of 1998.

34.3 If a bidder(s) or contractor(s), has / have been found guilty by the Competition Commission of the restrictive practice referred to above, the purchaser may, in addition and without prejudice to any other remedy provided for, invalidate the bid(s) for such item(s) offered, and / or terminate the contract in whole or part, and / or restrict the bidder(s) or contractor(s) from conducting business with the public sector for a period not exceeding ten (10) years and / or claim damages from the bidder(s) or contractor(s) concerned.

Js General Conditions of Contract (revised July 2010)

DEPARTMENT OF WATER AND SANITATION

BID W 1021(WTE)

THE SUPPLY AND DELIVERY OF 184 DIFFERENT FLANGES FULLY MACHINED, DRILLED AND NORMALISED AS
PER SUPPLIED DRAWINGS FOR CONSTRUCTION CENTRAL

SECTION 3: SPECIFICATIONS

CONTENTS

1. Conditions
2. Services
3. Quantities
4. Site
5. Standard Specifications
6. Products
7. Acceptance Criteria for Delivered Material
8. Testing of Material During the Contract Period
9. Scope of Contract
10. Quantities Required/Delivery Rate
11. Programme of Works
12. Payment
13. Road Conditions and Distance
14. Bidders vehicles
15. Cost
16. Specifications /Detail of Offer/ Pricing Schedule
17. Delivery
18. Delivery Period
19. Penalty for late delivery
20. Bid Price and delivery periods
21. Preference
22. Technical Information
23. Evaluation Criteria

NOTE:

Failure to indicate whether you comply or not comply in the Specification will invalidate the bid. (*Clearly indicate your compliance by either crossing out whichever is not applicable or circling whichever is applicable.)

SPECIFICATION

(*indicate clearly which is applicable)

1. CONDITIONS

In addition to the general conditions set out in the document "General Conditions of Contract", the following special conditions shall apply:

Comply / Not Comply

1.1 SUPPLIER OF PRODUCT

The successful bidder will be required to submit a "Letter from the manufacturer" confirming the supply arrangement within 14 days after the approval of the bid.

Comply / Not Comply

2. SERVICE

The service to be rendered is the supply and delivery of the following material to site:

Supply and delivery of 184 different flanges fully machined; drilled and normalised as per supplied drawings to Construction Central, As more fully specified hereunder.

Comply / Not Comply

3. QUANTITIES

The quantity required quantity is given in the SBD 3.2. Orders will be placed as and when requirements become known. Deliveries will be required days from date of the official order.

TAKE NOTE

4. SITE

Construction Central is located in Jan Kempdorp , 882 Van Riebeeck Avenue in Northern Cape.

The GPS co-ordinates are as follows:
27° 54' 52" S, 24° 49' 38" E

TAKE NOTE

Access to the site is via normal tar road

5. STANDARDS, SPECIFICATIONS AND DEFINITIONS APPLICABLE

Flanges:

1. All flanges shall be flat faced with a gramophone finish as per detail.
2. All flanges shall be in accordance with SANS 1123 table 1000/3.
3. 1800ND flanges: OD, PCD, hole Dia and No-off bolt holes to be in accordance with SANS 1123 table 1000/18.
4. Round all edges to a 2mm radius

Abbreviators:

TDC – Top Dead Centre
BDC - Bottom Dead Centre

(DO NOT SCALE DRAWING)

The bidders are required to supply the material that conforms to these specifications and standards of SABS 1431 and SANS 1123 and all flanges shall be in accordance with SANS 1123 table 1000/3 Mild steel grade 350WA in the form of their latest editions.

*Comply / Not Comply

*Comply / Not Comply

For the purpose of this specification the definitions and abbreviations given in the specification and standards and the following shall apply:

The Department have the right to inspect the material of all the Bidders to ensure whether sufficient quantities of material is available and whether the Bidder is in such condition to complete the contract. The inspection may take place before, during and after the award of the contract.

TAKE NOTE

6. ACCEPTANCE CRITERIA FOR DELIVERED MATERIAL

The delivered material will be accepted and regarded as being in accordance with the specification and the requirements.

TAKE NOTE

7. TESTING OF MATERIAL DURING THE CONTRACT PERIOD

Testing of material shall be in accordance with the particular requirements for its use as specified in the appropriate specification.

TAKE NOTE

The successful Bidder shall conduct all the tests specified in SANS 1123 grade 350WA or equivalent on the material to ensure that the quality of the material will comply with the specified requirements at any given time for the duration of the contract.

TAKE NOTE

The costs of all these tests shall be included in the unit price (bid price) given in SBD 3.2

TAKE NOTE

8. SCOPE OF CONTRACT

Bidder

The Bidder will be required to perform the following service as part of this contract:

(i) Transport material to site

TAKE NOTE

(ii) Stockpile material in designated locations

TAKE NOTE

(iii) Supply 184 different flanges in accordance with the specification and supplied drawings.

TAKE NOTE

9. QUANTITIES REQUIRED / DELIVERY RATE

The total quantity of material to be delivered will be 184 flanges.

TAKE NOTE

The Bidder will not be entitled to claim any form of compensation for any requirement variations in the total quantities or specific quantities whatsoever.

TAKE NOTE

10. PAYMENT

Payment will be made for all flanges. The Department reserves the right to check the quantities loaded at any time.

TAKE NOTE

Payment will be made monthly on receipt of specified tax invoices.

TAKE NOTE

Payment will not be made for consignment unless supported by delivery notes duly signed by the official checking the delivery and weighbridge certificates.

TAKE NOTE

Payment will be done within 30 days of receipt and approval of original invoice by depositing the payment directly into the bank account of the successful bidder. No cash or cheque payment will be done.

TAKE NOTE

Payment for standing time exceeding two hours will only be made if

TAKE NOTE

such standing time is a result of the action of the Department.

11. ROAD CONDITIONS AND DISTANCE

Bidders are advised to acquaint themselves with roads, road conditions, distances, etc. on and to the site, before bidding.

TAKE NOTE

12. BIDDER'S VEHICLES

The Department will have the right to instruct the successful Bidder to repair or replace a vehicle which is considered unsuitable for the transporting of the material.

TAKE NOTE

Overloading of vehicles in terms of the Road Traffic Act will not be permitted.

TAKE NOTE

13. COSTS

Bidders shall provide in their bid for all labour, plant, material, implements and vehicles necessary for the execution of the contract and all operating and maintenance costs in accordance with the bid documents.

TAKE NOTE

14. SPECIFICATIONS / DETAIL OF OFFER / PRICING SCHEDULE

Where the answer to the question "Is the offer strictly to specification" is "No", the Bidder shall state ALL the variations and the reasons, if necessary on a separate sheet.

TAKE NOTE

15. DELIVERY

Delivery to site is required to start 14 days after the receipt of the official order. It is a contractual requirement that the gravel wearing course be delivered as from the above mentioned time.

TAKE NOTE

The delivery address is:

**882 Van Riebeeck Avenue
Department Water and Sanitation**

Construction Central

Jan Kempdorp

8550

Northern Cape.

Deliveries may be made during the following working hours **06h30 to 15h00** from Monday to Thursday but **not** on the following days or periods:

TAKE NOTE

(i) Fridays 14h00 to Mondays 06h00

(ii) All public holidays

(iii) The period 11 December to 05 January

(iv) The last Friday of the month

If by any change a delivery is made outside of scheduled times the offloading will commence only the next working day and no standing time will be charged to the Department.

TAKE NOTE

The Bidder shall nominate a contract person with whom the Department will arrange and schedule deliveries. Purchase orders for material will be placed 48 hours before delivery is required.

TAKE NOTE

A SABS approved certificate of compliance shall be submitted by the Bidder showing the properties and grading of requested material.

TAKE NOTE

DWA Construction will perform testing and grading on all material delivered to ensure that all material do comply with the relevant specification. DWA will decline material that does not comply this load(s) will not be accepted and will not be paid for. The declined load(s) must be removed from site ASAP for the Bidders own cost.

TAKE NOTE

16. DELIVERY PERIOD

A firm delivery period is required. Adherence to bid delivery period is of utmost importance. Note that the penalty for late delivery prescribed in paragraph 17 of the Specification will be imposed.

TAKE NOTE

17. PENALTY FOR LATE DELIVERY

If the Bidder fails to supply the goods or render the service within the period stipulated in the contract, the Department shall have the right , in its sole discretion either to deduct as a penalty from the value of the contract sum an amount of one-fourteenth percent thereof per day for the period of delay or claim any damages or loss suffered in lieu of such penalty provided that where beneficial use of the completed portion is enjoyed, the penalty shall be applied to the value of the outstanding portion only.

TAKE NOTE

18. BID PRICE AND DELIVERY PERIODS

All inclusive bid prices are required, meaning VAT, delivery and any other cost mentioned in the specification for the Bidders account must be included in the unit price. Firm bid prices and delivery periods are preferred. The following considerations shall apply in evaluating bids with differing price and delivery conditions:

TAKE NOTE

18.1 Bidder may submit firm / non firm prices.

18.1.1 "Firm" prices are deemed to be the prices which are only subject to the following statutory change:

(a) VAT, (in the event that it is changed by government)

TAKE NOTE

(b) Any levy related to customs and excise (written proof must be given)

18.1.2 "Non-firm" prices are all prices other than "firm" prices as stipulated in paragraph 18.1.1.

TAKE NOTE

18.2 In cases where non-firm prices are offered, a breakdown of the bid price reflecting the different portions of the bid price that might fluctuate must be indicated. It shall be stated whether prices will be subject to escalation in accordance with the provisions of the Departments User Manual or proposed escalation formulas shall be stated.

TAKE NOTE

18.3 When calculating comparative prices, non-firm prices may be loaded.

TAKE NOTE

18.4 Where a Bidder has not indicated whether his prices or delivery periods are firm or not, the bid price and delivery periods are deemed to be firm and the Bidder shall be bound thereby. No exceptions will be made.

TAKE NOTE

18.5 Expressions such as "soonest" or "earliest" or delivery periods which are unspecified are not acceptable.

TAKE NOTE

19. PREFERENCE

Standard Bidding Form SBD 6.1 will apply. A maximum of 10 points will be awarded for B-BBEE status. A valid accredited B-BBEE Status Level Verification Certificate must be submitted with the bid document in order to claim points.

TAKE NOTE

20. TECHNICAL INFORMATION

Failure to complete the "Comply / Not Comply" column in the specification will result in the bid being disqualified as non-responsive.

Comply / Not Comply

If stated "Not Comply" reasons must be given for not comply with the specifications.

TAKE NOTE

Note: The Department reserves the right to change the quantity to be ordered from the successful bidder.

Comply / Not Comply

21. EVALUATION CRITERIA

The evaluation Committee will be following a phased approach during the evaluation.

Phase 1

Administrative Compliance:

Bidders are required to submit and or complete the following documents which should form part of the bid submitted by closing date. Omission to complete and/or submit the listed documents will render your bid non responsive and the bid will not be considered for the phase 2 evaluation.

TAKE NOTE

- (a) An original and valid tax clearance certificate
- (b) The pricing schedule (SBD3.2)
- (c) Completion and inclusion of standard bidding documents. (SBD1, SBD4, SBD6.1, SBD8, SBD9)
- (d) Proof of compliance certificate of SANS 1123 grade 350WA or equivalent or issued by other countries.
- (e) Compulsory briefing session should be attended (Signing of attendance register)

TAKE NOTE

Phase 2

Technical Compliance:

The bid will be evaluated using the below criteria and failure to comply with all the specifications as listed will render your bid as not to specification and non responsive and the bid will not be considered for the phase 3 evaluation.

- (a) Standard Specifications as set out under Section 3: Specifications and the compliance thereof
- (b) The bid will be rendered non responsive if the bidder fails to complete the "Comply / Not Comply" section in the Specification under Section 3: Specifications

TAKE NOTE

Phase 3

Evaluation of price and preference points claimed:

During this phase, bid proposals that passed the phase two will be further evaluated based on the 90/10 preference points system in accordance with the PPPFA Act, where 90 points will be attained in respect of price and 10 points will be awarded to a bidder for attaining the B-BBEE Status Level of Contribution in accordance with the table below:

B-BBEE Status Level of Contributor	Number of points (90/10 system)
1	10
2	9
3	8
4	5
5	4
6	3
7	2
8	1
Non-compliant contributor	0

In order to claim the B-BBEE Status Level of Contributor points, bidders must submit original and valid B-BBEE Status Level Verification Certificates or certified copies thereof, issued by accredited Verification Agency/s by SANAS or 11.2.3.2 Registered Auditor approved by Independent Regulatory Board of Auditor (IRBA), together with their bids to substantiate their B-BBEE rating claims. The Exempted Micro Enterprise must submit a letter from the Accounting Officer who is appointed in terms of Close Corporation Act.

TAKE NOTE

Bidders who do not submit B-BBEE Status Level Verification Certificates or are non-compliant contributors to B-BBEE do not qualify for preference points for B-BBEE but will not be disqualified from the bidding process. They will score points out of 90 for price only and zero (0) points out of 10 for B-BBEE.

Bidders are requested to complete the preference claim form in order to claim preference points. The points scored by a bidder in respect of points indicated above will be added to the points scored for price.

The highest ranked bidder will be awarded the bid. It should be noted also that the Department reserve the right not to appoint any service provider.

A person will not be awarded points for B-BBEE status level if it is indicated in the bid documents that such bidder intends sub-contracting more than 25% of the value of the contract to any other enterprise that does not qualify for, unless the intended sub-contractor is an EME that has the capability and ability to execute the sub-contract.

A person awarded a contract may not sub-contract more than 25% of the value of the contract to any other enterprise that does not have an equal or higher B-BBEE status level than the person concerned, unless the contract is sub-contracted to an EME that has the capability to execute the sub-contract.

22. If indicated "Not Comply" in the specifications above reasons/deviations can be stated below:

TAKE NOTE

DEPARTMENT OF WATER AND SANITATION

BID W 1021(WTE)

THE SUPPLY AND DELIVERY OF 184 DIFFERENT FLANGES FULLY MACHINED, DRILLED AND NORMALISED AS
PER SUPPLIED DRAWINGS FOR CONSTRUCTION CENTRAL

SECTION 4: SBD 3.2 – PRICING SCHEDULE

CONTENTS

PREAMBLE TO THE SBD 3.2 – PRICING SCHEDULE

SBD 3.2 – PRICING SCHEDULE

PREAMBLE TO THE SBD 3.2 – PRICING SCHEDULE

1. GENERAL

The SBD 3.2 forms part of the Contract Documents and must be read and priced in conjunction with all the other documents which include the Conditions of Contract and all other Specifications in the bid document.

2. QUANTITIES REFLECTED IN THE PRICING SCHEDULE

The quantities given in the SBD 3.2 can be subject to change. The Department reserves the right to purchase a lesser/higher quantity as indicated in the SBD 3.2

The validity of the contract will in no way be affected by differences between the quantities in the SBD 3.2 and the quantities finally certified for payment.

3. PRICING OF THE SCHEDULE

The rates to be filled in the SDB 3.2 should include all costs. All rates and amounts quoted in the SBD 3.2 shall be in Rand and shall include VAT.

4. CORRECTION OF ENTRIES

Incorrect entries shall not be erased or obliterated with correction fluid but must be crossed out neatly. The correct figures must be entered above or adjacent to the deleted entry, and the alteration must be initialled by the Bidder.

**PRICING SCHEDULE
(Firm / Non Firm Price)**

BID W 1021(WTE)

THE SUPPLY AND DELIVERY OF 184 DIFFERENT FLANGES FULLY MACHINED, DRILLED AND NORMALISED AS PER SUPPLIED DRAWINGS FOR CONSTRUCTION CENTRAL

THIS PRICING SCHEDULE MUST BE COMPETED IN FULL – FAILURE TO COMPLY WILL INVALIDATE YOUR BID

NOTE: PRICE ADJUSTMENTS WILL ONLY BE ALLOWED AT THE PERIODS AND TIMES AS SPECIFIED IN THE BIDDING DOCUMENT

CLOSING TIME 11:00 ON:	BID NO.: W 1021(WTE)
NAME OF BIDDER:	

OFFER TO BE VALID FOR 60 DAYS FROM CLOSING DATE OF BID

ITEM	DESCRIPTION	UNIT	RATE VAT EXCL	Qty	AMOUNT VAT EXCL
1	A: Flanges (1000ND) as per drawing	each		16-off	
2	B: Flanges (60ND) as per drawing	each		3-off	
3	C: Flanges (700ND) as per drawing	each		7-off	
4	D: Flanges (200ND) as per drawing	each		14-off	
5	E: Flanges (300ND) as per drawing	each		48-off	
6	F: Puddle Collar (600ND) as per drawing	each		42-off	
7	G: Thrust Collar (600ND) as per drawing	each		3-off	
8	H: Thrust Collar (1800ND) as per drawing	each		29-off	
9	I: Thrust Collar (1000ND) as per drawing	each		18-off	
10	J: Blank Flanges (Ø1990) as per drawing	each		4-off	
					-
SUB TOTAL					R
VAT @ 14%					R
**TOTAL BID PRICE					R

NOTE: ALL FIELDS ON THIS FORM SHOULD BE COMPLETED IN FULL. IF A FIELD IS NOT APPLICABLE, THE FIELD SHOULD BE INDICATED AS "NOT APPLICABLE". THE DEPARTMENT OF WATER AFFAIRS WILL NOT ENTERTAIN ANY CLAIMS FOR NON-FIRM PRICES INCREASES CLAIMED AT A LATER DATE, UNLESS SUCH NON-FIRM PRICE ADJUSTMENTS ARE CLEARLY MOTIVATED IN THIS FORM.

- Required by: Construction Central
- At (Place of delivery): Jan Kempdorp
- Delivery basis: To Site
- **Period required for delivery after receipt of order:**days
- Delivery period: * FIRM / NOT FIRM
- If not firm state deviation(s)
- Is the price firm? * YES / NO
- If the price is not firm state the escalation formula / period:
(Please see note above)
- Does the item offered comply with any recognise Standards body, e.g. SABS? NOT APPLICABLE
- If so furnish valid certificate to this end NOT APPLICABLE
- Is offer strictly to specification? * YES / NO
- If not to specification, state deviation(s)
- Is all the relevant information filled in completed in the "Comply / Not Comply" under Section 3 of the bid document * YES / NO
- Has samples being submitted for testing? * YES / NO

*****"All Applicable Taxes" includes value-added tax, pay as you earn, income tax, unemployment insurance fund Contributions and skills development levies.**

NOTE: All delivery costs must be included in the bid price.
Failure to complete all the relevant information in SBD 3.2 will render your bid as non-responsive.

Any enquiries regarding bidding procedures may be directed to the –
Department of Water and Sanitation
Supply Chain Management Office
Private Bag X6, Jan Kempdorp, 8550.
Tel: (053) 456 0508

Or

For technical or site information –

Mr. Johan Oosthuizen

Tel: (053) 456 0508 during office hours

1230

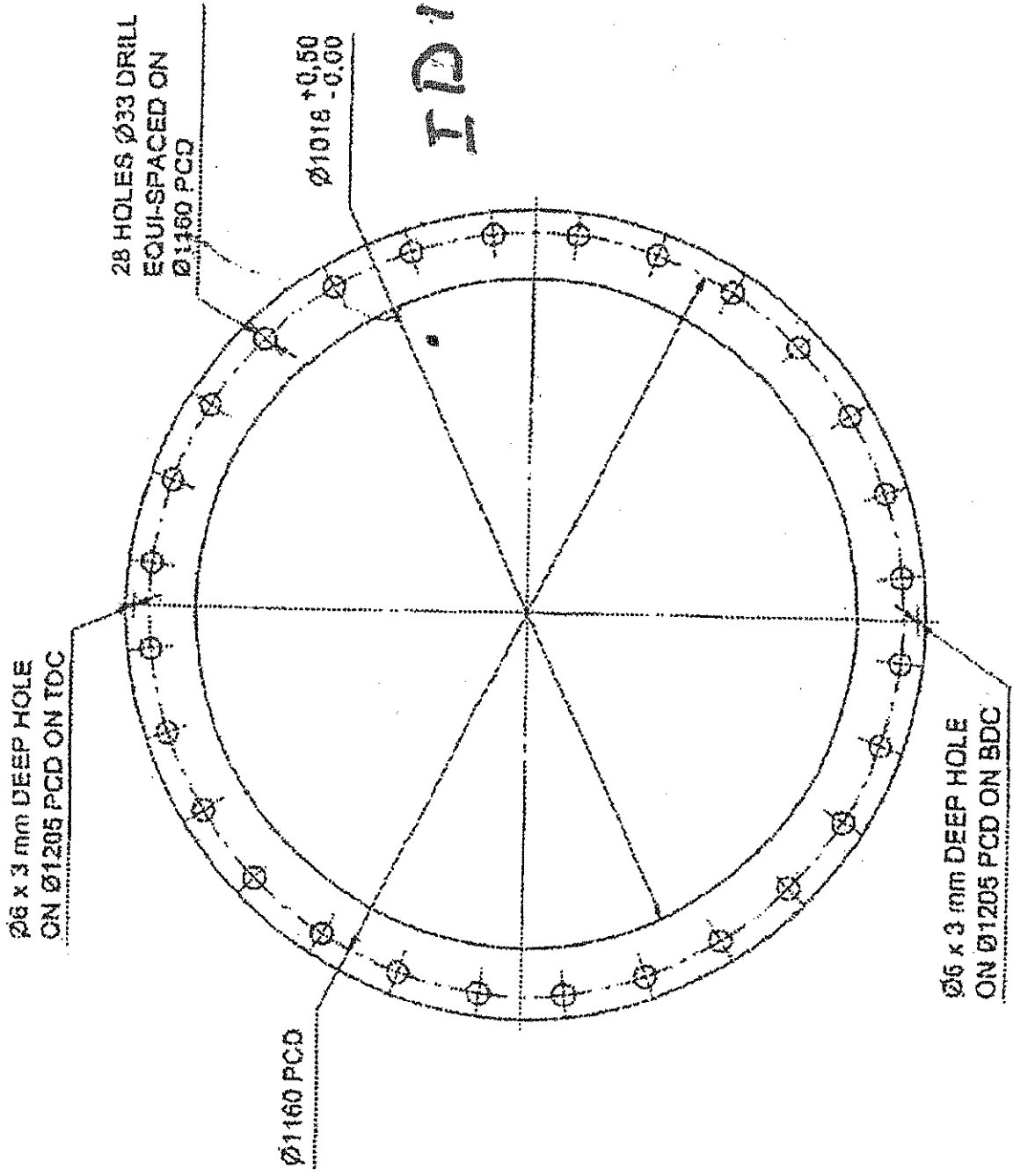
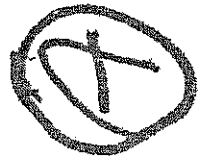
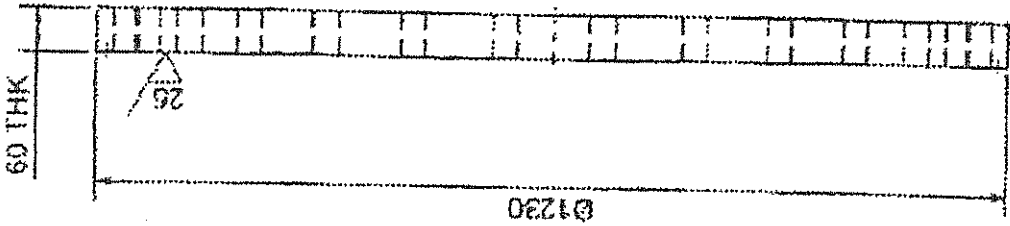

ID 1018

NOTE A:
MACHINE ONE FACE ONLY AS SHOWN.

A	FLANGE - TO SUIT DN 1000 PIPE	SIZE	1000
		MATL	MR.D STEEL

ON Ø755 PCD ON TDC

38 THK

Ø725 PCD

Ø612 $+0.50$
 -0.00

7.5L

Ø6 x 3 mm DEEP HOLE
ON Ø755 PCD ON BDC

20 HOLES Ø26 DRILL
EQUI-SPACED ON Ø725 PCD

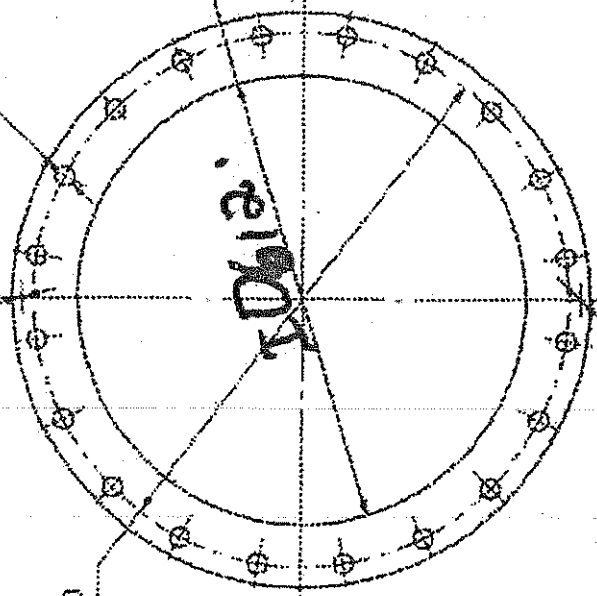

B

NOTE A:
MACHINE ONE FACE ONLY AS SHOWN.

FLANGE - TO SUIT DN 600 PIPE

MATL	MILD STEEL	MASS	52 kg
NO OFF	3	SCALE	1:5

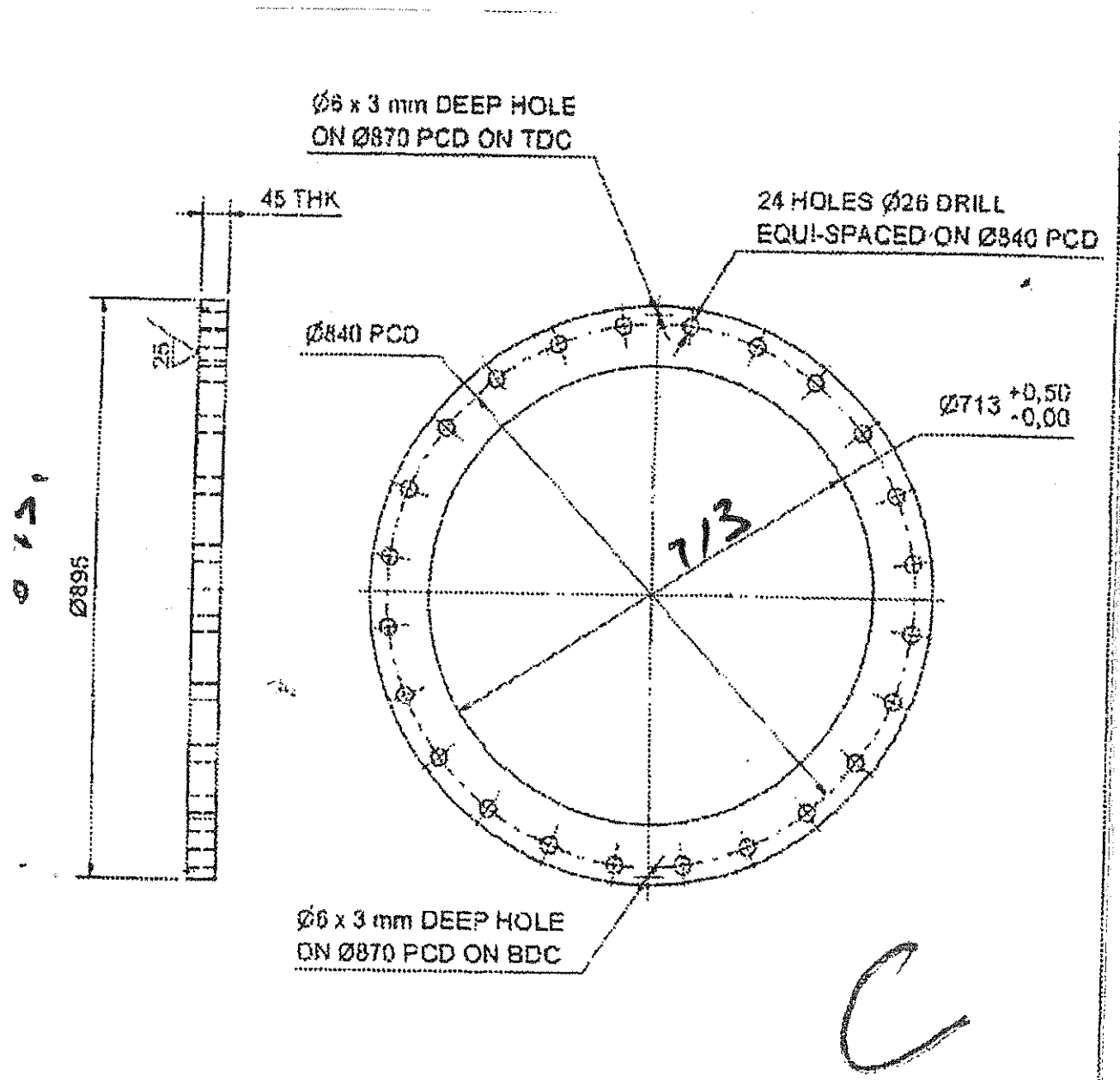

NOTE A:
MACHINE ONE FACE ONLY AS SHOWN.

(C)	FLANGE - TO SUIT DN 700 PIPE
QUANTITY	MATERIAL
	THICKNESS
	77 kg

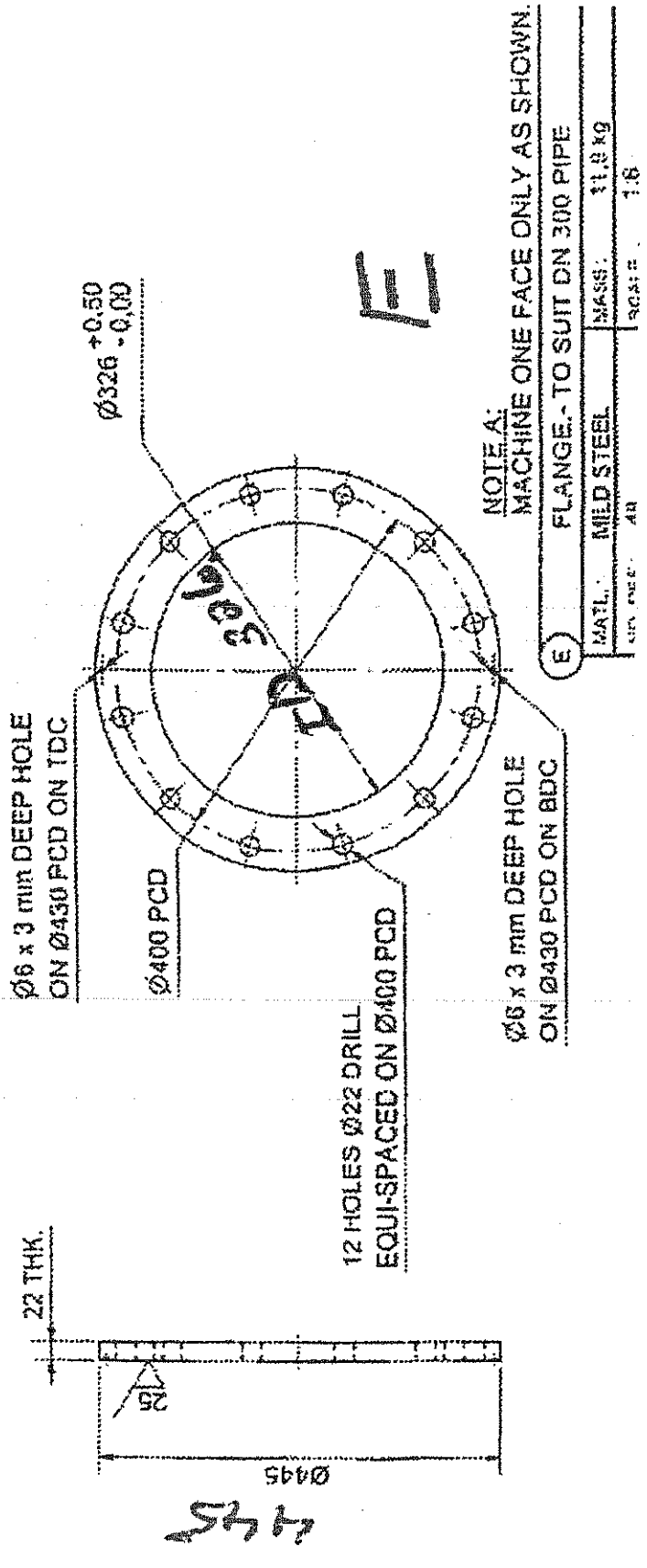
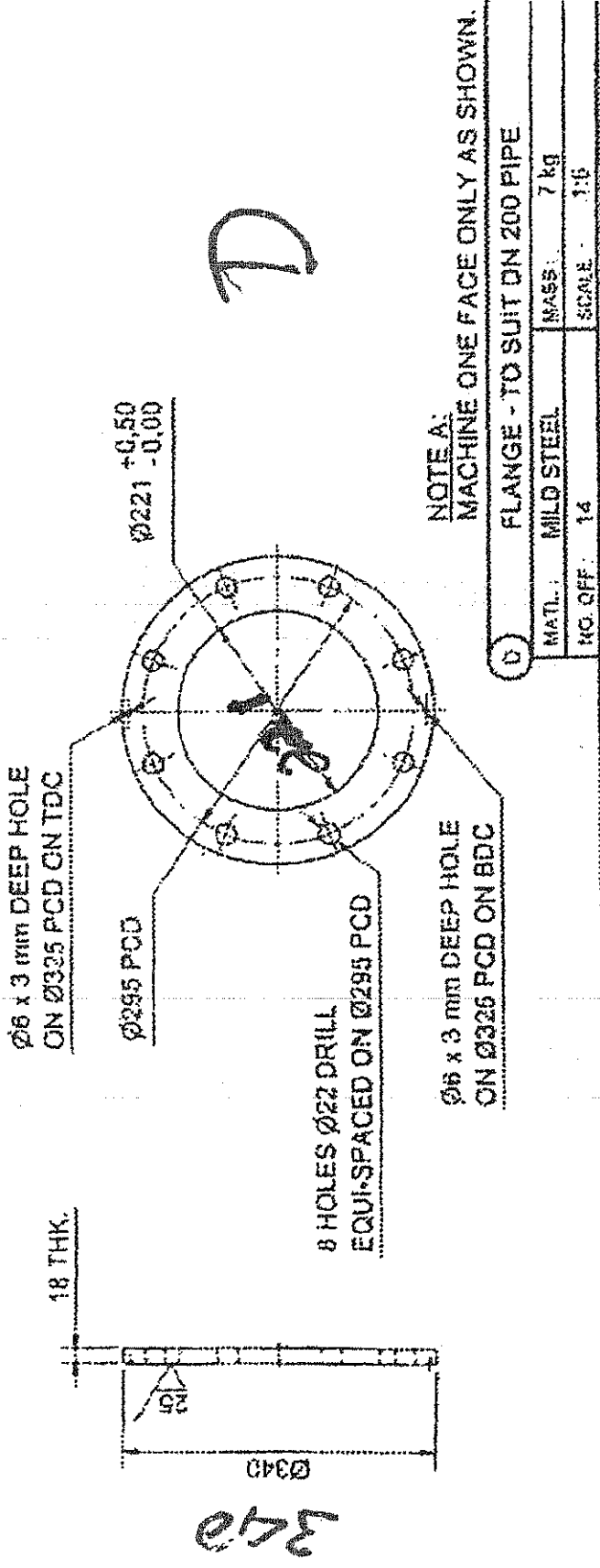

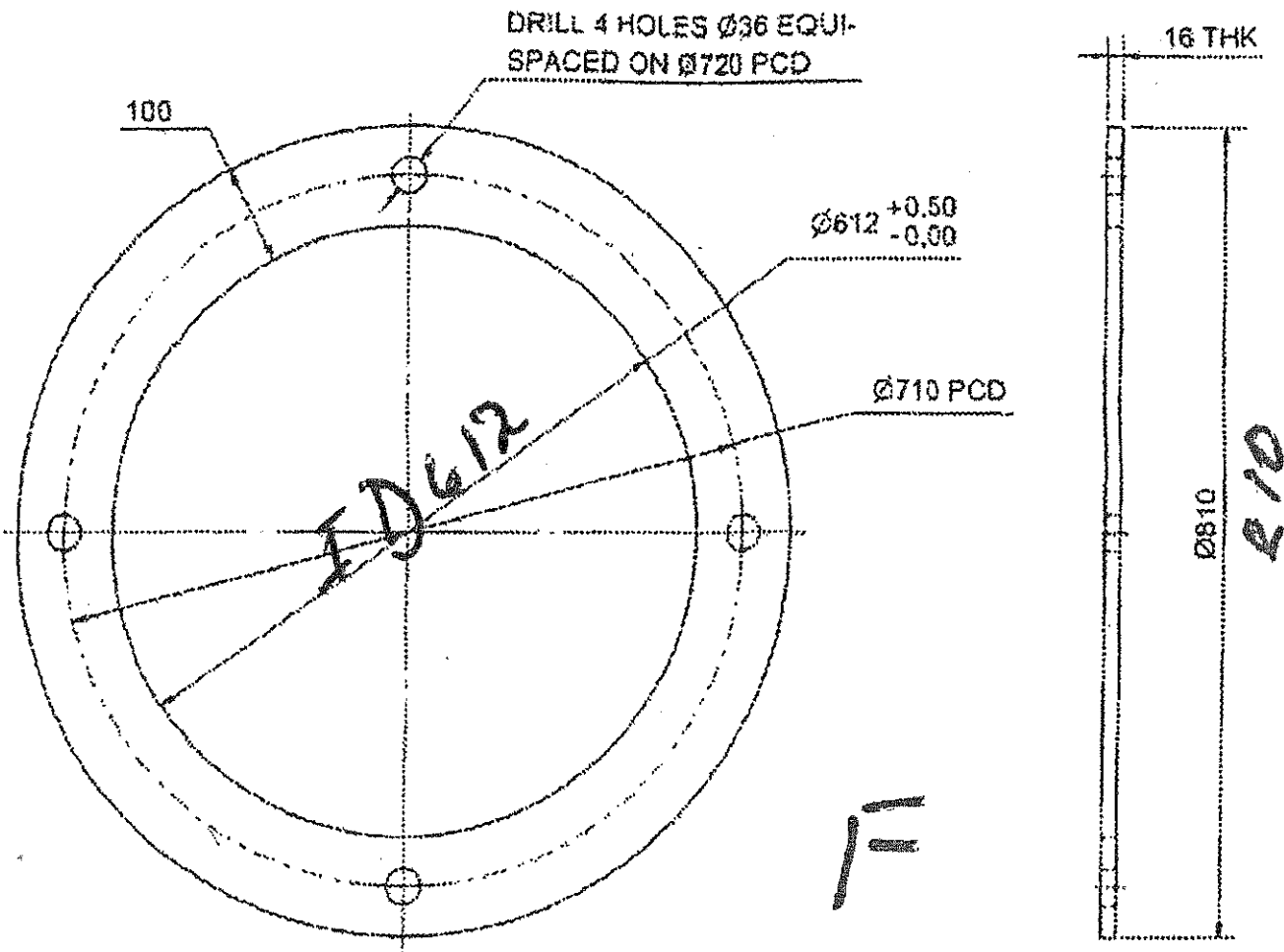

NOTE B:
NO FACE MACHINING REQUIRED.

F PUDDLE COLLAR - TO SUIT DN 600 PIPE			
MATL.	MILD STEEL	MASS :	27.5 kg
NO OFF.	42	SCALE :	1:6

Ø6 x 3 mm DEEP HOLE
ON Ø750 PCD ON TDC

12 HOLES 220° SPACED ON TDC
AND SLOT AS PER DETAIL 'A'

30 THK.

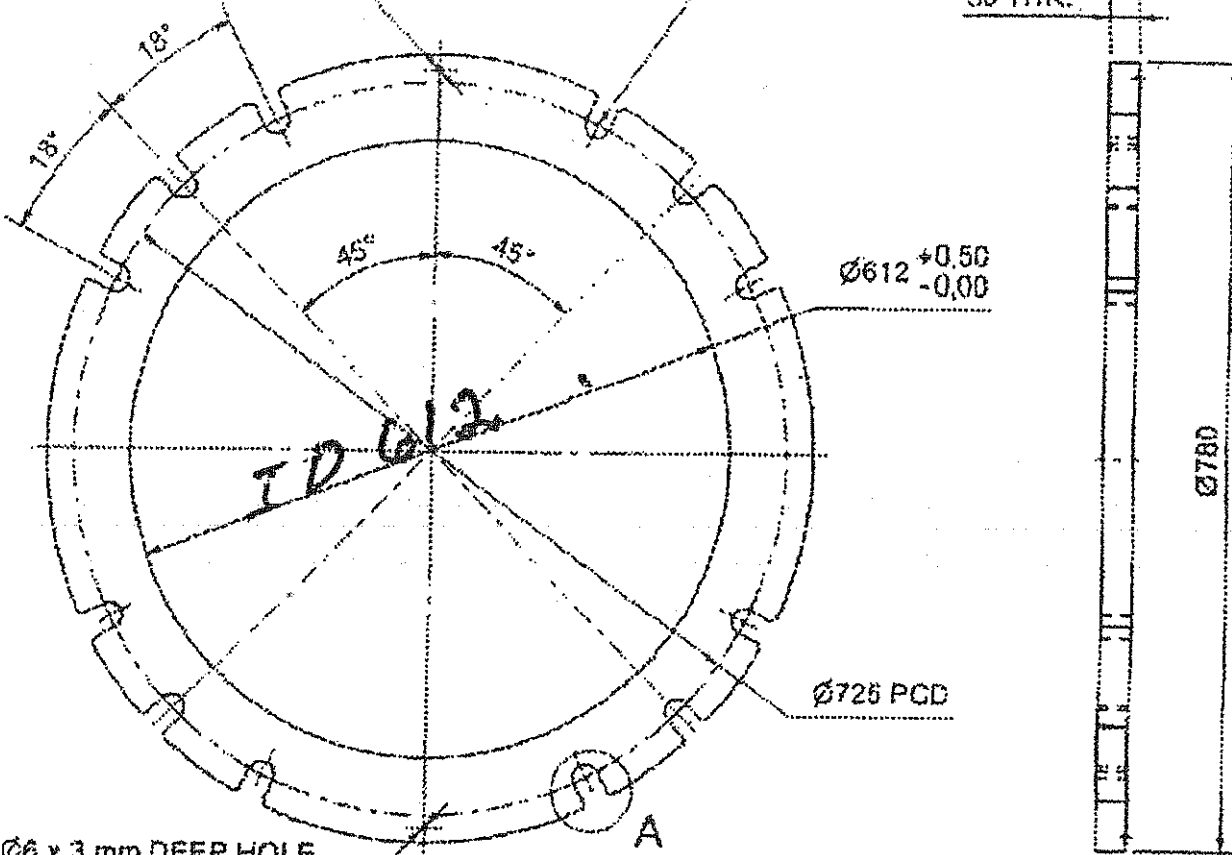

Ø6 x 3 mm DEEP HOLE
ON Ø750 PCD ON TDC

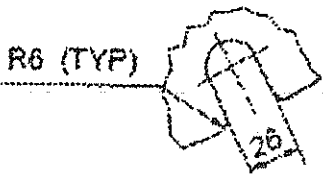

DETAIL A
SCALE 1:3

NOTE B:

NO FACE MACHINING REQUIRED.

G THRUST COLLAR - TO SUIT DN 600 PIPE			
MATL.	MILD STEEL	MASS:	41 kg
NO. OFF.	3	SCALE:	1:0

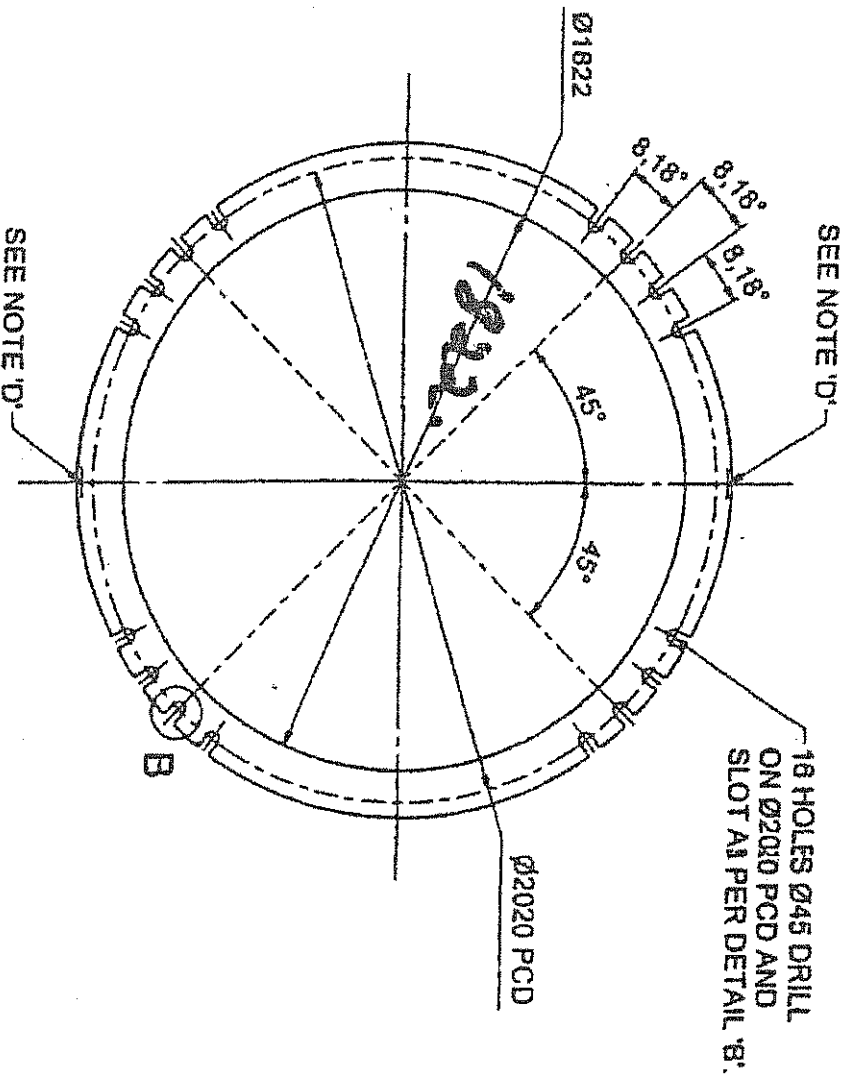

**TYPICAL DETAIL OF
THRUST COLLAR - 1800 NB**
SCALE 1:18

SEE NOTE 'D'
18 HOLES Ø45 DRILL
ON Ø2010 PCD AND
SLOT A1 PER DETAIL 'B'.

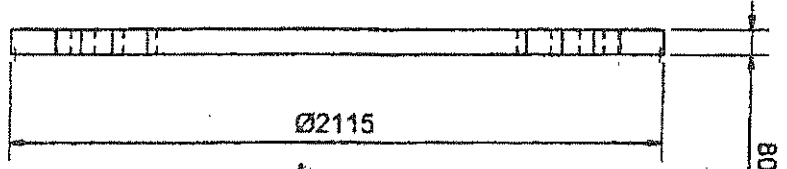

*NO FACE MACHINING REQUIRED, ONLY
INSIDE DIAMETER OF COMPONENT.

NOTE 'D':
Ø6 x 2 mm DEEP HOLE ON Ø2090 PCD ON TOP /
BOTTOM DEAD CENTRE. (FILL WITH SIGNAL RE
PVC PAINT AFTER FINAL CORROSION PROTEC

DETAIL 'B'
SCALE 1:5

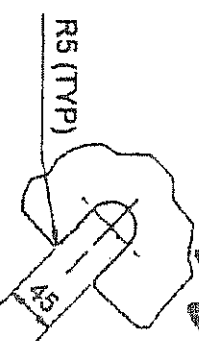

Handwritten notes:
5/11/19
229 off



18 dfb

45 THK MILD STEEL

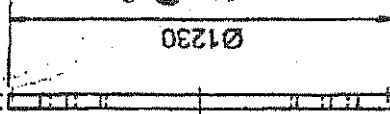

*NO FACE MACHINING
REQUIRED, ONLY
INSIDE DIAMETER OF
COMPONENT*

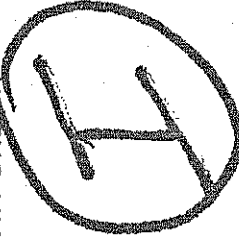

SEE NOTE 'C'
12 HOLES Ø33 DRILL
ON Ø1160 PCD AND
SLOT AS PER DETAIL 'A'

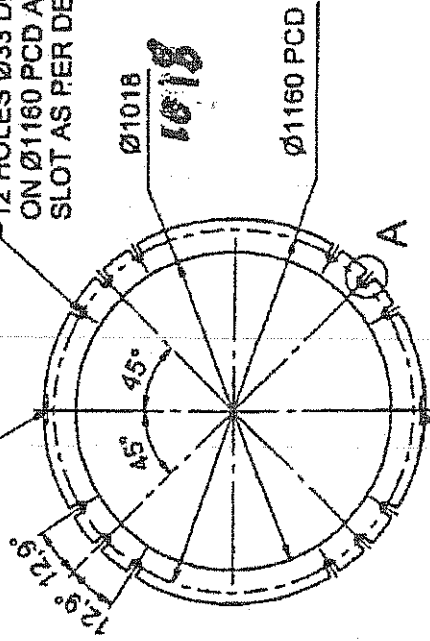

SEE NOTE 'C'

**TYPICAL DETAIL OF
THRUST COLLAR - 1000 NB**

SCALE 1 : 10

NOTE 'C'
Ø6 x 2 mm DEEP HOLE ON Ø1205 PCD ON TOP AND
BOTTOM DEADCENTRE. (FILL WITH SIGNAL RED
PVC PAINT AFTER FINAL CORROSION PROTECTION.)

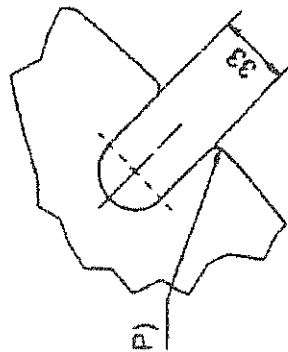

DETAIL A
SCALE 1 : 2.5

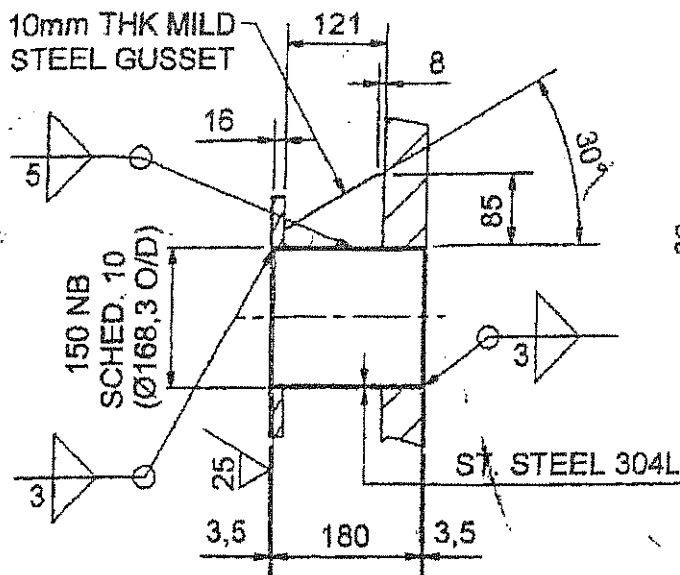

DETAIL E
SCALE 1 : 7.5

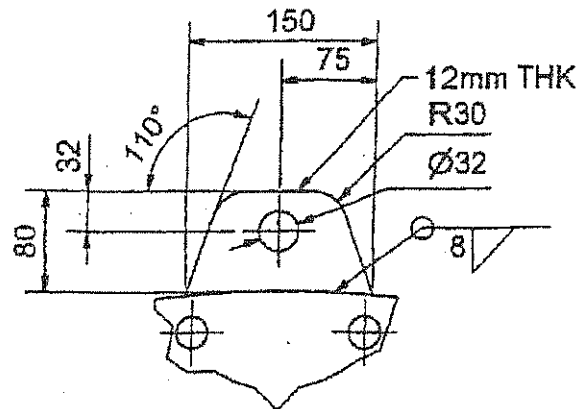

DETAIL F
SCALE 1 : 5

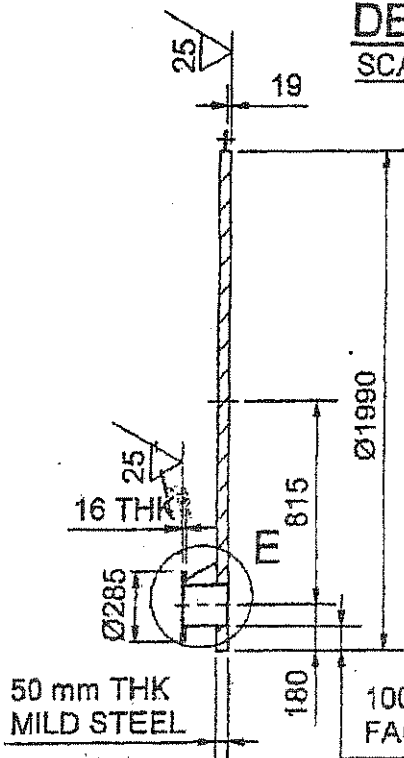

SECTION A-A
SCALE 1 : 25

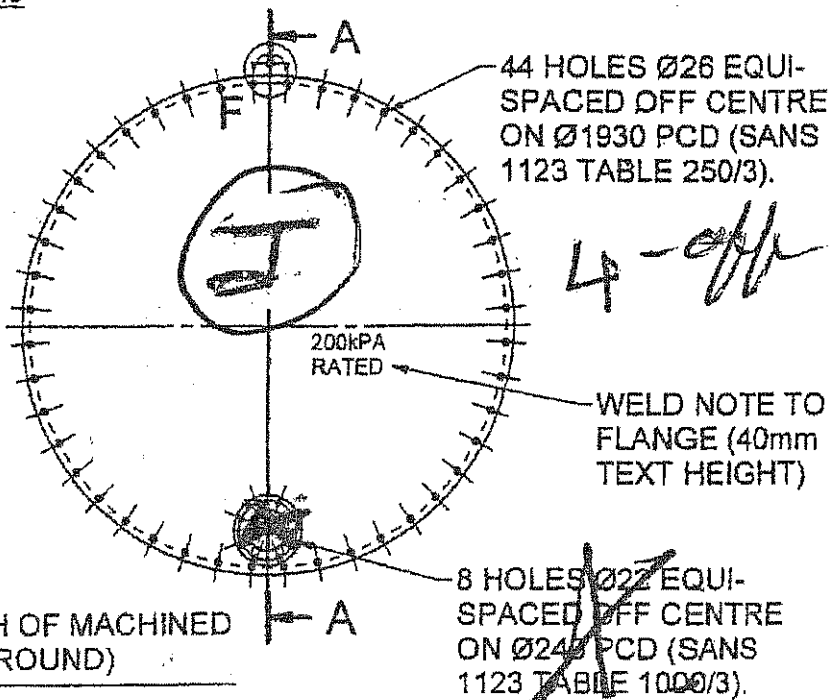

(10) BLANK FLANGE	
MATL. : MILD & ST. STEEL	MASS : 1215 kg ea.
NO. OFF : 4	SCALE : 1:40

